

Indoor climate systems

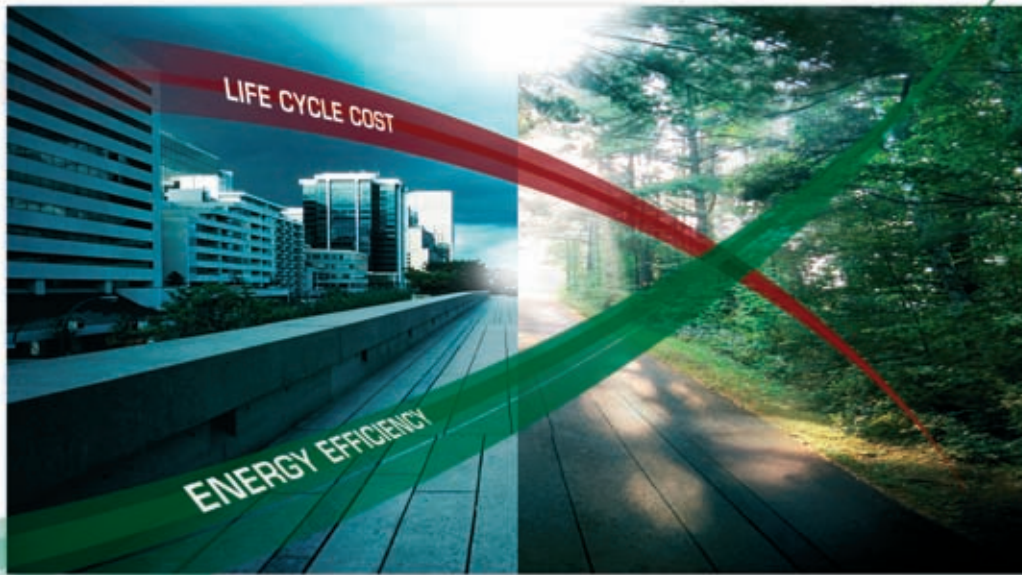

Indoor climate systems

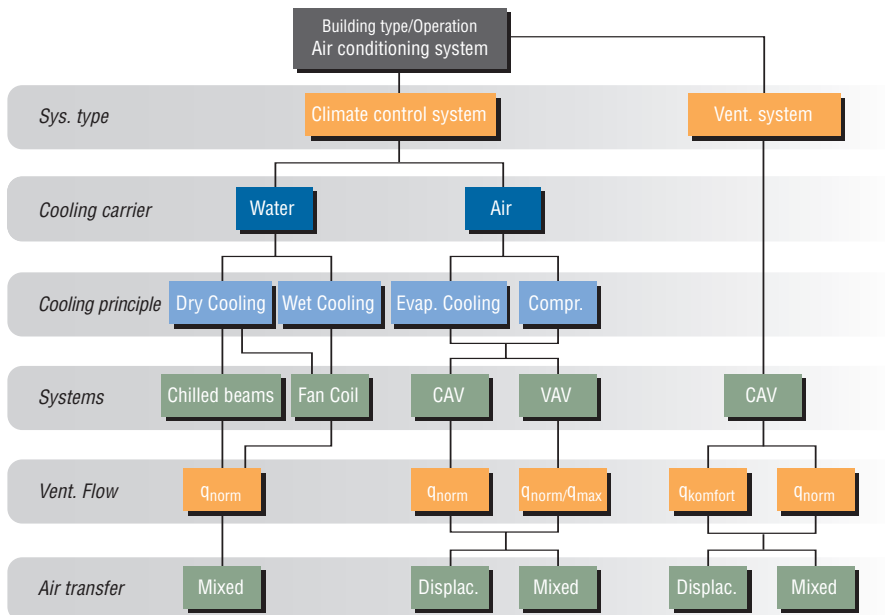

Aim of the manual

This manual on Fläkt Woods indoor climate systems is aimed at anyone who comes into contact with the indoor climate system of a building. Developers, project managers, fitters, operations managers, environment managers — all these people are examples of groups who make technical, financial and environment-related decisions which are influenced by the arrangement of indoor climate systems. With this manual, we aim to provide you with an overview of the system solutions we recommend for buildings of various kinds. The solutions we propose represent modern climate technology and are tried and tested in practical applications.

To-do list

How to plan using this manual

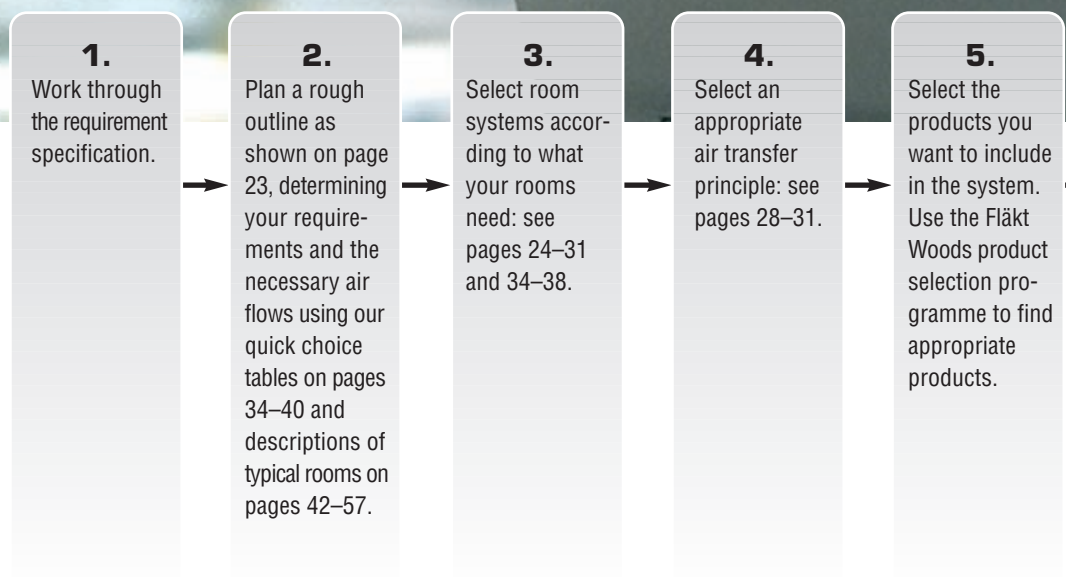

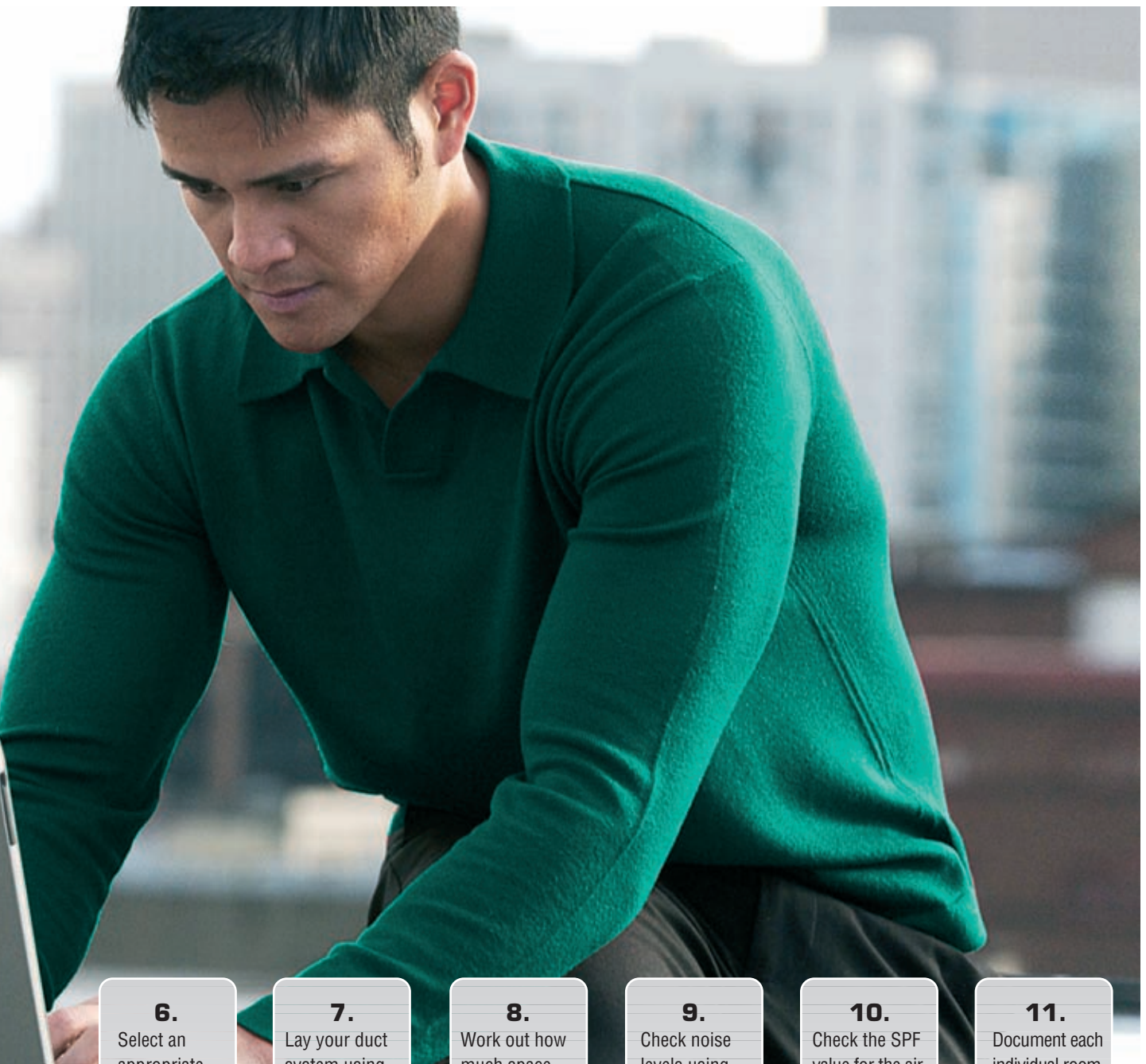

6.

Select an appropriate heat recovery unit for your air conditioning system: see page 84.

7.

Lay your duct system using the correct dimensions to be sure of having enough space for it. Use the complete system illustrations on pages 58–67 as a template.

8.

Work out how much space you require in the unit room, the weight of the unit and its electrical output and heating/cooling effect.

9.

Check noise levels using noise data from the Fläkt Woods product selection programme.

10.

Check the SPF value for the air conditioning system, and where necessary also calculate the LCC cost of the system: see pages 98–99.

11.

Document each individual room using the form on page 126.

© Fläkt Woods Group

Production: CCJ Kommunikation 08.08

Printed by: Tabergs Tryckeri

Printed on Tom & Otto Silk, chlorine-free paper.

Contents

INTRODUCTION

Aim of the manual	9
Presentation of the manual	11

DEFINE REQUIREMENTS

The job of the system	15
Temperature requirements	16
Air quality requirements	18
Document climate requirements	20

SELECT AN INDOOR CLIMATE SYSTEM

Before choosing your system	23
Combine several systems	24
One combination system	25
Four basic room systems	26
Exhaust air control	27
Select air transfer	28
The benefits and restrictions of these methods	31
To-do list	32
Select a system	34
Select systems for offices	36
Select systems for schools and nurseries	36
Select systems for libraries	37
Select systems for hospitals	37
Select systems for shops and department stores	38
Select systems for banks/large offices	38
Select systems for hotels	39
Select systems for restaurants	39
Select systems for theatres and cinemas	40
Select systems for light industry	40
Typical rooms	42
Typical room A: Storeroom	46
Typical room B: Small office	48
Typical room C: Small office, stringent requirements	50
Typical room D: Conference room	52
Typical room E: Large office	54
Typical room F: Care room	56
Tips on selecting systems and products	58
A constant flow system	60
A variable flow system	62
A system using waterborne cooling	64
One combination system	66
Home ventilation	68

REFERENCE SECTION

The right room temperature	76
Temperature and economy	78
Heating and cooling	80
Calculate the cooling effect correctly	81
System selection matrix and air transfer	82
Heat recovery	84
Econet heat recovery	88
Airborne cooling	90
Fan coils	92
VAV	93
Chilled beams	94
Perimeter wall systems	96
Energy-efficient systems	98
Electricity-efficient fans	100
Control and regulation equipment	102
DCV	103
Fire protection systems	105
Product option programme	108
EPBD	109
The environment and quality	110
Noise in air conditioning systems	113
Noise level calculation	114
References	123
Terms and definitions	125

APPENDIX: FORMS AND DIAGRAMS

126



Introduction

Aim of the manual

Five important points

This manual on Fläkt Woods indoor climate systems is aimed at anyone who comes into contact with the indoor climate system of a building. Developers, consultants, project managers, fitters, operations managers, environment managers – all these people are examples of groups who make technical, financial and environment-related decisions which are influenced by the arrangement of indoor climate systems. With this manual, we aim to provide you with an over-view of the system solutions we recommend for buildings of various kinds. The solutions we propose represent modern climate technology and are tried and tested in practical applications. What we have to offer can be summarised in five points:

1 Pays off

An air conditioning system, compared with a simple ventilation system, pays off by providing better efficiency and also ensures that people feel more comfortable in the workplace.

2 Several levels

You can make your own decision about what you invest in your climate. In an individual climate, each and every person can choose the temperature they want, while in a collective climate all you can do is make sure the temperature does not rise to an unpleasant level. No matter what level you select, your investment will pay for itself quickly. Of course, choosing an individual climate will cost a little more, but efficiency will also increase to a greater extent.

3 Air flow determines air quality

When you choose an indoor climate system, air quality is a very important climate factor. The quality of the air is determined in the first instance by the outdoor air flow supplied, and secondly by the filter quality and air transfer principle. On premises where humans and electrical units are the primary sources of pollution, removal of smells is the dimensioning factor. To achieve good air quality, you normally need a greater air flow than that prescribed by the construction rules of the National Board of Housing, Building and Planning: flows of up to 15–20 l/s are not uncommon in order to achieve good air quality.

4 Planning room by room

Each room in the building has to be studied individually, independently of other rooms. Doing this will allow you to develop a system which meets your needs precisely.

5 Large air flows require regulation

As soon as the air flow exceeds what is required for ventilation, the flow must be controlled according to requirements. Small or large regulation zones can be used for this. Increasing the air flow beyond what is required for ventilation, but without regulating the air flow, is an unnecessary waste of energy.



Developing technology

Our knowledge of the significance of the indoor climate and its effects on people, the environment and energy costs has increased of late, and people have really begun to value both good air quality and adapted temperatures. At the same time, commitment to the issue has been passed on to people other than ventilation engineers.

Examples include:

- The development of energy costs has forced system designers to devote themselves much more than before to the energy consumption of their systems.
- Computer engineering aids are permitting more accurate calculations, with more parameters being taken into account.
- Computer simulation is an important element.

Systems in which a number of different subsystems are combined under a collective unit with a constant duct pressure can be expected to become the standard solution in future. A system of this kind combines flexibility and adaptation to requirements to a design which is optimal from a financial standpoint.

Knowledge of the significance of the indoor climate in respect of concentration and performance has increased, resulting in greater focus on the development of products and systems. Quite simply, there's money to be made from comfort in the workplace.

Research shows that it is not only humans that give rise to stale air which has to be vented out into the at the moment: various building materials and interior fittings do too. Moreover, over the last few years we have learned considerably more about the significance of air movement to people's perception of comfort.

Presentation of the manual

Define requirements

This manual will start off with a brief review of the data you need to hand to allow you select the most appropriate system solution for a specific room.

This data will form part of the overall requirement specification. The rest of the requirement specification will essentially influence the choice and design of the products used to make up the system. A detailed example will show you how to systematise input data retrieval.

Select an indoor climate system

Combine the systems

Fläkt Woods' advice and recommendations for choosing an air conditioning system can be found in the section entitled *Select an indoor climate system* on page 22. The main principle is that you need a collective air conditioning unit which provides the duct system in the building with supply air at a certain temperature and moisture. A system which includes this kind of a unit can ideally be used to mix constant flow systems and variable flow systems. Additional cooling from chilled beams or fan convectors can be readily integrated into the system where so required.

Select a system according to the requirements of the room

This section contains a description of a number of basic ways of passing air and heating/cooling into a room. We provide recommendations for a number of typical rooms which represent most of the cases which a planner may encounter. These recommendations are based on our experiences of various types of building.

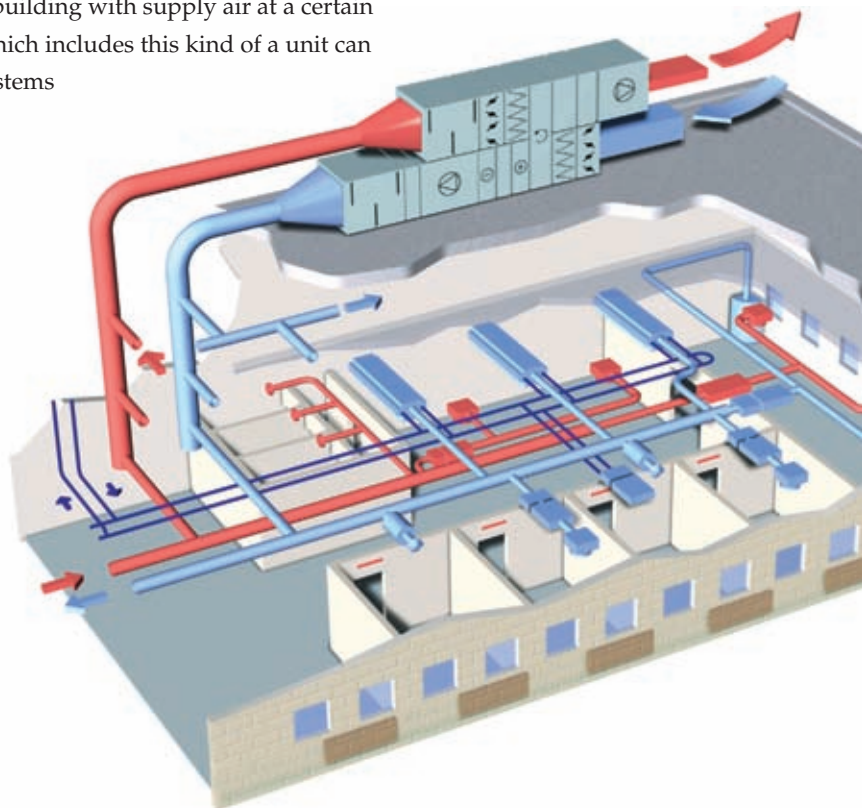

Quick choice

The solutions recommended by Fläkt Woods in various types of room and building are depicted in our quick choice tables, which refer to typical rooms.

Planning in two stages

PRELIMINARY PLANNING

Carrying out preliminary planning with the aid of this manual will give you a very good idea of what you will need for your system within just a couple of hours. Using Fläkt Woods product catalogues and design programmes, you can find some very accurate information on issues such as:

- cooling effects
- air flow
- type of indoor climate system
- power output to unit
- heating/cooling effect to unit
- VAS class and SFP_v value
- appropriate control and regulation methods
- LCC (Life Cycle Cost)

DETAILED PLANNING

The cooling effects are calculated using the current values in order to increase accuracy. You then follow the same procedure as during preliminary planning, but with the difference that all documents are now completed.

Reference section

The *Reference section* on page 74 contains technical information which might help you during specification and planning. Instructions on how to select and assess the room temperature can be found there. Why should a modern air conditioning system be proposed? How can we justify the additional expense?

We also demonstrate here how important it is to carry out accurate calculations of the requirement for cooling effect so that you do not need to deal with unnecessary, costly overdimensioning.

The reference section also contains information on various recovery systems, energy-efficient air distribution systems and electricity-efficient fans. We briefly describe terms such as LCA, CE labelling and quality and environmental labelling systems in the section entitled *Environment and quality* on page 110.

Finally, we point you in the direction of information on some interesting specialist literature in various fields.





Define requirements

The job of the system

The primary tasks of an air conditioning system are:

- To remove unclean air and replace it with clean air
- To provide the right temperature

In this section, we will take a moment to look at the requirements important for outline planning of the system. Find out more about the background to the requirements in the *Reference section* on page 74.

THE CLIENT'S REQUIREMENT SPECIFICATION

Indoor climate requirements should be adapted to suit what is to be done in the building and the people who work there. These must be specified in the client's requirement specification. Therefore, the specification must state what the client requires from the indoor climate (thermal comfort, air quality, noise level, and so forth).

Note that the client — normally the developer — is responsible for the content of the requirement specification and its usefulness as a basis for planning.

EFFECTS OF CORRECT PLANNING

Setting requirements is the first thing you need for a successful system. After that, of course, you have to design your system directly on the basis of these requirements.

A correctly projected system is characterised by:

- high air quality being maintained
- air movements not causing discomfort, such as draughts
- the temperature remaining within the required boundaries
- the climate being adapted to requirements in all parts of the building
- a low noise level
- ambient humidity remaining within set limits
- easier servicing
- costs being kept low

In the case of existing systems, the indoor climate must not be adversely affected when energy-saving measures are implemented in the building. This is why planning executed correctly is a must even in the case of modernisation and replacement projects.

Temperature requirements

Everyone is different

People all have different views on what the right climate is. Different people perceive the same climate differently depending on what they are wearing, what they are doing and how old they are. In a collectively regulated climate, such as an open plan office, 80% of people are usually happy while the others think it is either too cold or too hot.

Different requirement levels

Three different requirement levels can be used as a basis for planning:

A — Simple ventilation, no upper temperature limit

B — Collectively regulated climate

C — Individually regulated climate

The three levels lead to different qualities in respect of the indoor climate and correspond to different cost levels as regards the investment. If you also include the income side of things, such as an increase in efficiency, the relationships between the three levels are altered. Find out more about this in the *Reference section* on page 74.

When you choose a requirement level, it is important for you to know what it involves; otherwise there is a risk of disputes once the system has been supplied. It has happened in the past that the requirements set by the client during planning have resulted in a simple ventilation system. When the system was then commissioned, the client expected it to offer the same performance as a fully fledged climate system.

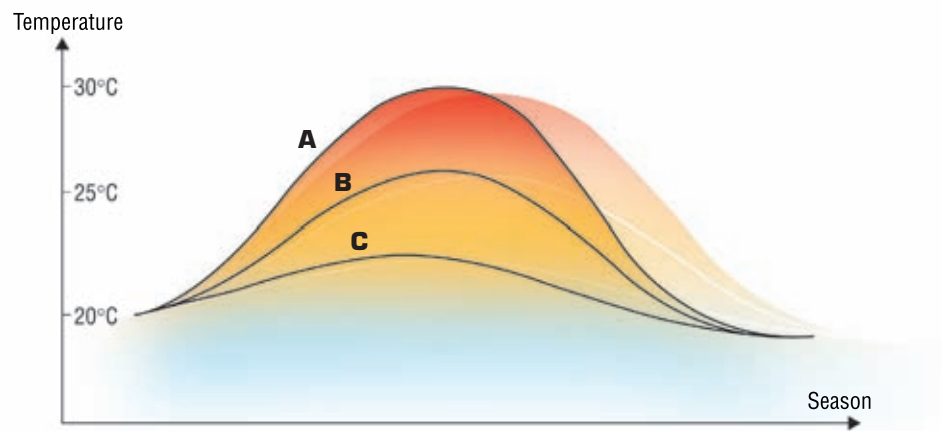

Level A — Simple ventilation, no upper temperature limit

The building regulations BBR2006 of the National Board of Housing, Building and Planning do not specify an upper temperature limit. This means that the room temperature is permitted to rise above the limits which represent a comfortable climate and a good working environment. In the case of systems planned simply on the basis of the building regulations, it is not uncommon in summer to find such rooms at temperatures in excess of 30°C.

Requirement level A results in the lowest investment cost. Depending on what kind of activity the premises are designed for, other standards and provisions may be of relevance. In the case of workplaces, for example, the provisions of the Swedish Work Environment Authority — which also include requirements in respect of the thermal requirements of the premises — are applicable.

Level B — Collective climate

Where rooms are similar and under moderate loads, it is possible to design a climate which is regulated collectively. The temperature is restricted in such rooms so as to ensure that they do not end up being unpleasantly hot. Room temperature must be maintained at a level which is normally considered to be comfortable; that is to say, the temperature is normally slightly above the ideal so that the most sensitive individuals do not feel cold. Your target should be to ensure that no more than 10% of the people in the room are unhappy with the temperature.

Systems for rooms with a collective climate are usually designed to maintain a room temperature of 23°C–26°C. At least in the southern and central parts of the Nordic Region, this means that air conditioning units have to be equipped with air coolers.

Requirement level B requires a slightly higher investment cost than level A. The cost of investment can be reduced if short periods of higher room temperature can be accepted. As long as the outdoor temperature is below 5°C, the cooling requirement can often be met without using an air cooler.

The climate is a lot better than in the case of level A. Greater efficiency means that the system soon pays for itself.

Level B corresponds to TQ2 in accordance with the recommendations of the R1 (Guidelines for Indoor Climate Requirements).

Level C — Individual climate

Individual room regulation is selected

- in the case of large loads and loads which vary widely
- when you have stringent requirements in terms of efficiency and comfort

If the climate is regulated individually, you can set more stringent requirements for your system's ability to maintain a low room temperature than when the climate is regulated collectively. Anyone who thinks it is too cold can then select a slightly higher room temperature.

An individually regulated climate costs more to install than a collective regulated climate. But as efficiency increases still further if people are able to choose their own individual temperatures, this more complex system also pays for itself very quickly, often in less than a year.

Level C is equivalent to TQ1 in the Guidelines for Indoor Climate Requirements (R1) of the VVS-Tekniska föreningen. Find out more about efficiency and economy in *Temperature and economy* on page 78.



Set requirements by room

You normally find different requirement levels represented in a building. And it is important to set your requirements for each individual room on the basis of what the premises are used for. Only then will you have a system which meets your actual needs. An appropriate temperature range depends largely on the level of users' physical activities and the insulating properties of their clothing.

Air quality requirements

Ventilation and air quality

Sealed buildings, less floor space per person, new materials for construction and interior fittings – these all mean that the quality of the air is being focused on more and more. We hear about “sick houses” almost every day. Research carried out over the past few years has shown that the need for ventilation due to interior fitting materials may be many times greater than the need for ventilation caused by the presence of humans. In the future, we can hope to see some form of technical ventilation classification of construction and interior fitting materials.

According to the building regulations of the National Board of Housing, Building and Planning, both humans and other sources of contamination must be taken into account. However, the outdoor air flows in this provision assume that emissions of contaminants from construction materials, for example, are low. Therefore, it is natural for the air flows in general to be perceived as small. Air quality is affected primarily by the size of the air flow, and secondly by the filter quality, supply air temperature and supply air method.

Sufficient air flow

In cases where the construction materials or interior fittings are not particularly troublesome with regard to ventilation, the air flow should be at least 10 litres per second and person. This normally results in one air change per hour.

The Swedish Work Environment Authority also specifies requirements for hygienic limit values and measures to counter air pollution, which in some cases may mean that the air flow required has to be higher. In this respect, air pollution refers to a substance, or a mixture of substances, in the air at a content which may cause problems or ill-health. Examples of such problems may include runny eyes, irritated mucous membranes in the nose and throat, but also smells which may be non-hazardous in and of themselves but can cause inconvenience for anyone on the premises.

Air rate

In winter, the air rate caused by ventilation should not be higher than 0.15 m/s. The corresponding rate for the summer should not exceed 0.25 m/s. Higher rates are perceived as draughts. These values apply in order to attain TQ2 in the R1.

To meet the highest level, TQ1, the air rate in winter must not be higher than 0.10 m/s, and in summer a maximum of 0.15 m/s is required. From experience, we have seen that air rates below 0.15-0.20 m/s, depending on the time of year, are perceived by most people as not causing a draught.

Quality of the supply air

The quality of the supply air is dependent partly on the position of the outdoor air intake, and partly on the class of filter used. The outdoor air intake must be positioned in a manner which takes into account the proportion of contaminants in the outdoor air. A minimum filter class of F 7 should be used for comfort systems in major cities. With modern climate technology, there is no reason at all to use return air in order to save energy, and this is why systems using return air should be avoided entirely.

To ensure good air quality, fans also have to be positioned so that leakage does not occur due to unwanted pressure differences in the heat recovery unit between the exhaust air side and the supply air side.

Ambient humidity

If there are requirements for a minimum ambient humidity during the winter, the air conditioning unit is fitted with an air humidifier. In such cases, it may be application to use hygroscopic rotary heat exchangers. The ambient humidity in the room will then be recovered at an efficiency of approx. 75%, thereby saving a lot of energy for humidification.

If there are requirements relating to the maximum ambient humidity in summer, the air conditioning unit can be fitted with an air cooler to dry the air. Too high an ambient humidity may lead to inconvenience, as well as mould growth and higher gas emissions from materials and equipment.

To allow you to study the properties of the air in more detail, there is a Mollier diagram on page 128.

□ FLÄKT WOODS RECOMMENDS

- Dimension the air flow to give at least 10 litres per second and person.
- The ventilation system should be designed to ensure that the entire occupation zone is ventilated.
- Requirement control of ventilation not only creates a better climate but also saves energy.
- Outdoor air intakes are positioned so that the supply air is not contaminated by extract air, traffic, etc.
- Avoid using return air.
- Provide the system with class F7 filters as a minimum.

For more information on air quality, see *References* on page 123.

Document climate requirements

Document requirements

Modern climate systems are designed so that every room or uniform group of rooms can benefit from a climate adapted to suit requirements. For the planner to be able to select the right indoor climate system for the various rooms, the client has to specify the right climate. It is important to ensure that these requirements are documented carefully so that there are no disputes later on what was ordered.

SIDE EFFECTS

To achieve the required indoor climate (temperature, air quality and noise level), the system is dimensioned in accordance with calculations performed. This is why it is important for the planner to check whether the client's requirement specification is reasonable, i.e. can be implemented with no troublesome side effects.

If there is a very large requirement for cooling effect (over 80 W/m²), such as where there are large expanses of glass, there are often problems involved with removal of excess heat.

Cooling effects which are too high can lead readily to draughts and may result in unnecessarily high investment and operating costs. Therefore, check that the air flow and cooling effect per m² of floor area are reasonable. The cooling output requirement may often be reduced using sun screens positioned outdoors, for example.

□ SOME GUIDELINE VALUES FOR COOLING OUTPUT REQUIREMENTS:

Small	< 30 W/m ²
Moderate	30–40 W/m ²
Medium	40–60 W/m ²
Large	60–80 W/m ²
Very large	> 80 W/m ²

Also check the anticipated noise level against set requirements and applicable standards.

The following form shows an appropriate way in which to collate and present facts prior to planning work. Technical criteria (outdoor climate, thermal loads, etc.) and room climate requirements (temperature, air quality, etc.) must be stated in the form. Work on the basis of the client's requirement specification. Divide the building into zones with similar requirements. Specify criteria and requirements for each room or group of rooms. Details common to the entire building, such as location, building type and dimensioned outdoor temperatures, are specified in the form header. *The form can be found on page 126.*

REQUIREMENT SPECIFICATION

Objects Kvarteret Framtiden Date 07.06.28

Type of building Kontor Town Ålvjö

Operating time 06.30-18.00

Dimensioned outdoor temperature, winter, DOT_w -18 °C Moisture content, winter — g/kg

Dimensioned outdoor temperature, summer, DOT_s +25 °C Moisture content, summer 10 g/kg

Other common criteria Samtliga fönster 3-glas

SHEET _____

Room no	Description	TECHNICAL CRITERIA						REQUIREMENTS						Comments		
		Floor-area m ²	Number of persons	Lighting capacity W	Machine capacity W	Windows	Other information	Temperature values °C			Min air change chs/h	Min air flow l/s	Ind./coll. regulation (INDV/KOLL)		Max. air rate at t _{max} m/s	Max. noise level dB(A)
								t _{ref}	t _{max}	t _{min}						
1-5	Småkontor	14	1	270	200	2	Öster	22	25	20	—	10	Ind.	0,2	33	Utv. solavsk.

SEA VF/SE 3979

COLLECTIVE TASKS

Dimensioned outdoor temperature, DOT

Both dimensioned outdoor temperature in summer, DOT_s, and dimensioned outdoor temperature in winter, DOT_w, are included in the table.

TECHNICAL CRITERIA

Description. The buildings referred to are specified here.

Number of people. Used as a basis for calculating heat from people. If strenuous physical activities are deeded to occur (in gyms, for example), this may be stated in the notes column.

Lighting capacity. Specified as installed capacity, including the throttle effect in the case of fluorescent lighting.

Machine capacity. Specified as the capacity from machines, taking into account any intermittent operation.

Window data. Window area, any sun protection, etc. affecting the radiation of solar heat are specified here. Specify in more detail in the notes column.

Other. Here, you can add details such as special humidity emission from swimming pools, service life, etc.

t_{ref} The normal temperature reference value. It is appropriate to temporarily accept a temperature deviation which deviates from the reference value so as to utilise the

building's heat accumulating properties and hence to reduce the installed cooling and heating capacities.

t_{max} The upper limit for normal temperature variation.

t_{min} The lower limit for normal temperature variation.

Min. air flow/air replacements. Specify the required air quality by stating how many room volumes are to be replaced per hour, or alternatively state a minimum air flow per person and second.

Maximum air movement. The maximum acceptable air rate in the occupation zone at t_{max} in summer. At a higher room temperature, a slightly higher air rate may be approved.

Individual/collective regulation. State whether the room is used so that collective regulation of several similar premises can be approved.

Maximum noise level. The maximum permitted noise level generated by the air conditioning system. Specified in dB(A). Take into account all sources of noise in the room.

Requirements are specified for some types of buildings in the building regulations of the National Board of Housing, Building and Planning. For the system to be perceived as comfortable, the standard's values for sensitive rooms should be reduced by approx. 5 dB(A). For normal offices, 35 dB(A) is a common value.



Select an indoor climate system



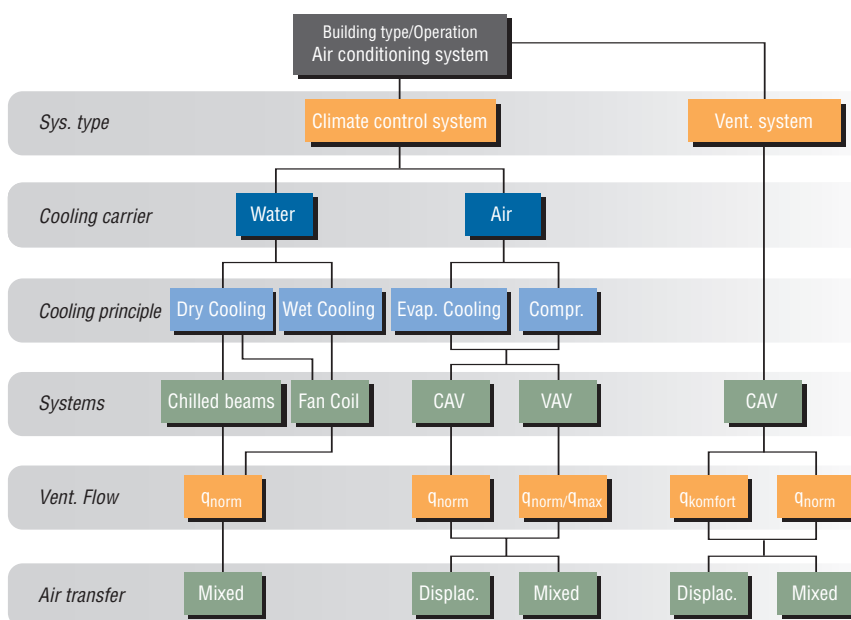

Before choosing your system

Outline planning

Planning work is executed in accordance with the requirement specifications and criteria specified by the client and which were described previously on pages 14–21.

Start by working out the cooling output requirement and requisite air flows; see the descriptions of typical rooms on pages 42–57. This is done firstly by room as a basis for a choice of an appropriate indoor climate system. Add together the capacities in order to select the unit size required, etc. Find out more about calculating cooling output requirements in the *Reference section* on page 74. Pages 32–33 show a summarised to-do list of the various stages.

Form

It is a good idea to use the following form or a similar arrangement to collate the results. This form is a continuation of the form for the requirement specification as described on page 21. As you come up with solutions, you can fill in device types, terminal units and other results from your work. The form in A4 size can be found at the back of the manual: see page 126.

PROPOSAL FOR TECHNICAL SOLUTION

Object: Kvartier Frankfurt Date: 02.06.28 SHEET _____

Type of building: Kontor Town: Augs

Kommentar: _____

GENERAL							PRODUCT SELECTION				
Room no.	Description	Cooling capacity W	Max. air flow l/s	Min. air flow l/s	Heating power W	System choice Typical rooms	Air transfer: Mixed / displaced	Device type Supply air	Terminal unit type	Device type Exhaust air	Comments
1-5	Small office	350	60	10	--	VAV/C	Mixed	CTEL	EMOS	-	Medium-sized silencer

SEAWIFRE 0980

Combine several systems

Select a system according to the requirements of the room

You normally have different requirement levels for different rooms in a building:

- A** — Simple ventilation, no upper temperature limit
- B** — Collective climate (collective temperature regulation)
- C** — Individual climate (temperature regulation on a per-room basis) thus it is also natural to select for every room the room system that best meets the requirements.

REQUIREMENT LEVEL	ROOM SYSTEMS
Simple ventilation (Level A)	Constant air flow, CAV. Fläkt Woods recommends that in the case of air flows higher than what is just required for ventilation, the system should be implemented as a VAV system (see below) with large regulation zones.
Collective climate (Level B)	Variable air flow VAV, with large regulation zones and moderate installed cooling effect.
Individual climate (Level C)	VAV, fan convector (fan coil) or chilled beam, depending on cooling effect and air movement requirement.

Select an air conditioning unit that can handle all systems

(CAV, VAV, FAN CONVECTORS AND CHILLED BEAMS)

In a modern system, a central air conditioning unit is normally used which feeds a duct system with constant pressure. A pressure control ensures that the pressure is kept sufficiently constant irrespective of the current total air flow.

The supply air is kept at a constant low temperature by means of either heating or cooling, depending on the outdoor temperature. If the supply air needs to be heated, the heat content of the exhaust air — which can be recovered using heat exchangers — is used in the first instance.

You can simultaneously connect both variable air flow systems and constant air flow systems to an air conditioning unit of this type. The unit can be supplemented with functions for waterborne cooling.

More and more frequently, we are seeing units with integrated control and regulation equipment so as to maintain the correct temperature and pressure in an energy-efficient way. These units can also be equipped with a data communication option; for instance, with monitoring systems for the operation and maintenance of the building. This provides a universally applicable and flexible unit for the building.

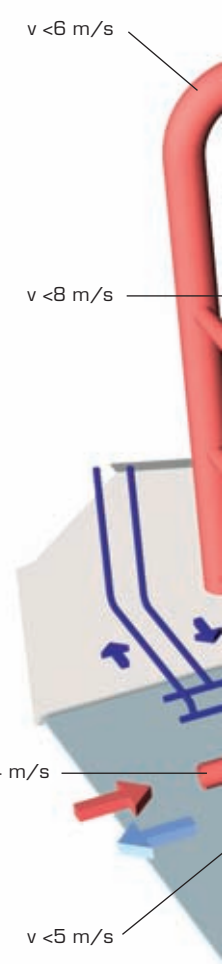

One combination system

Combine room systems

A combination system in a building may be designed as follows. The system is operated by a unit which maintains a constant supply air pressure and temperature.

Offices, hospitals and department stores are all examples of buildings where combination systems in general are the best solution, as these buildings include room types with widely varying cooling requirements.

Find out more about planning combination systems on pages 66–67.

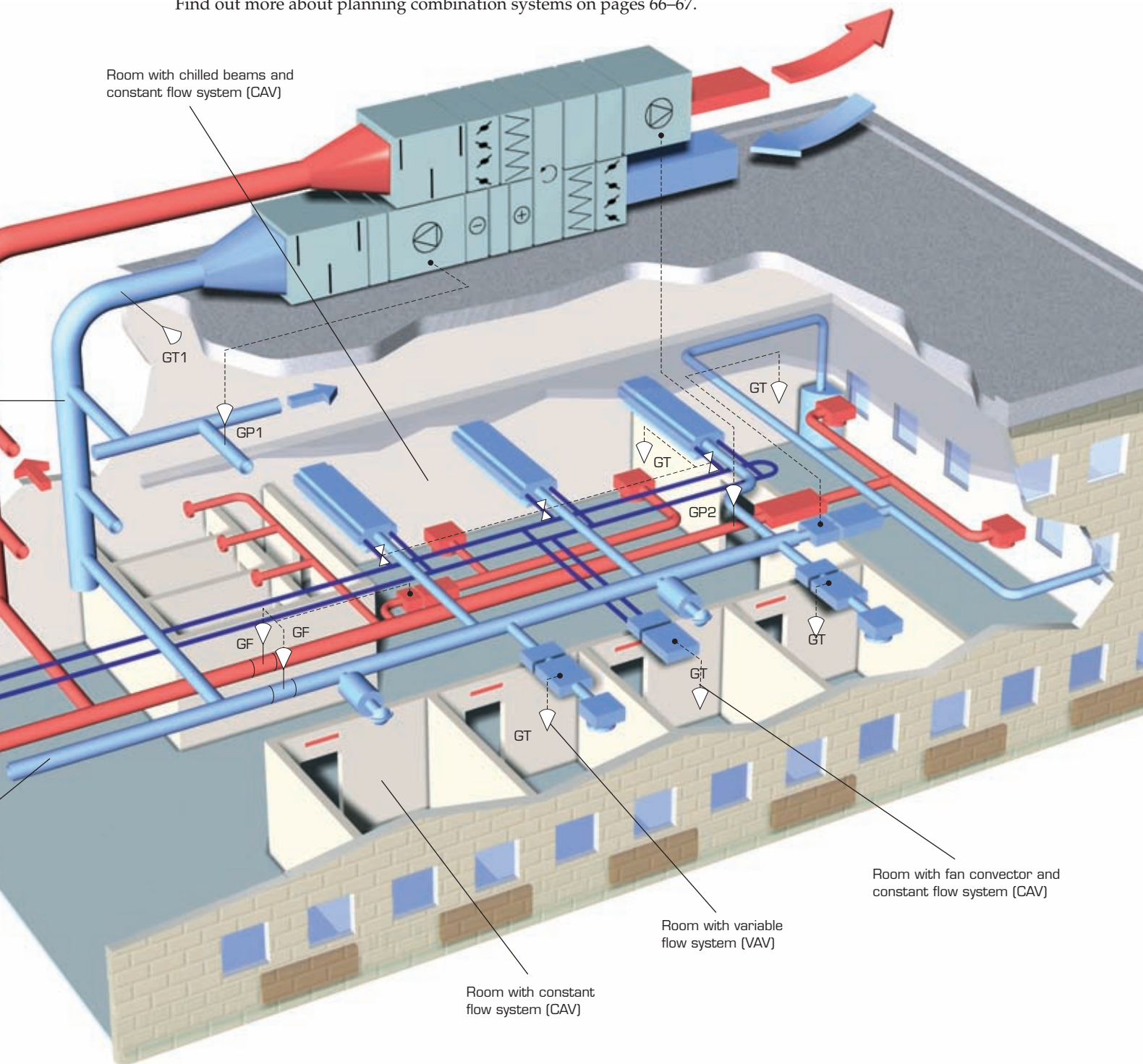

Four basic room systems

Room systems with constant air flow (CAV)

In a CAV system, the supply air and exhaust air flows are constant and independent of how heat generation varies on the premises. The air flow is set so that it is able to remove contaminants and excess heat under normal circumstances. If heat needs to be supplied, this can be done using a radiator or by post-heating the supply air.

For a CAV system, the following points are applicable:

- There should be relatively little need to remove heat.
- A system with a low investment cost, appropriate for small air flows.

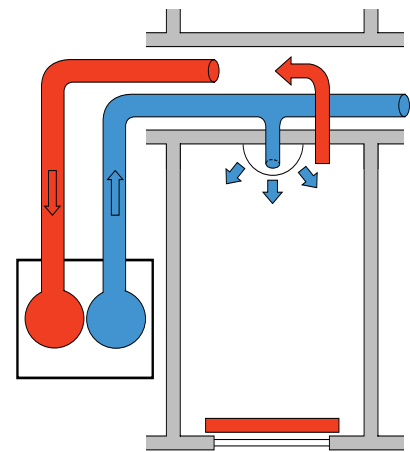

Room systems with variable air flow (VAV)

The air flow varies in a VAV system. The system uses a small air flow where there is a small requirement, and more air is used in the case of larger requirements. The minimum flow is set according to the normal ventilation requirement, while the maximum flow is determined by the maximum requirement for removing heat and contaminants.

For a VAV system, the following points are applicable:

- Suitable for use in the event of major load variations. The flow should be regulated in order to achieve good comfort and operating economy.
- The option of being able to freely select the size of the regulation zone ensures good price flexibility.
- Option for collective or individual regulation of the flow, using rooms sensors which detect temperature, presence, carbon dioxide content, air quality, moisture, etc.

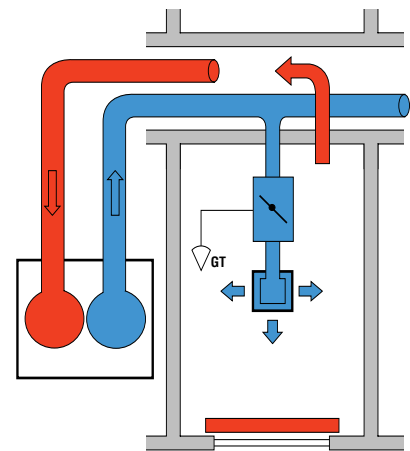

Room systems with fan convector (fan coil)

If there is a major requirement for heat removal, waterborne cooling is often a good idea. In an air system supplemented with a fan convector, ventilation and climate control are separated. The supply air system is used only for ventilation. The flow is determined by the ventilation requirement. A fan convector in the room circulates the room air through a water coil in which the air is heated or cooled as required. The fan operates at a number of rates and can be shut off if so required.

For a system with a fan convector, the following points are applicable:

- Individual temperature regulation is always included.
- Capacity available for fast cooling or heating all year round.
- Reduces the amount of space required for ducting.
- Appropriate for combination with heat pump operation.
- Risk of high air rate in the occupation zone under large loads.

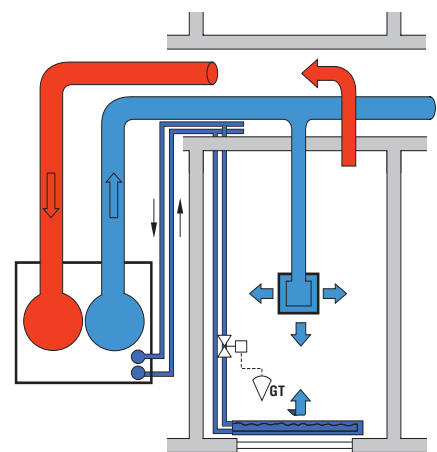

Room systems with chilled beams

A chilled beam essentially emits its cooling by convection (circulating room air passes through a cooling coil). Supply air can either be supplied with the chilled beam or with a separate supply air device. The first option provides the greatest cooling effect. The supply air flow is dimensioned only for ventilation and moisture control, while at the same time providing basic cooling. The chilled beam's coil is responsible for most of the cooling, which is regulated by means of a control vent for one or more beams, depending on the flexibility required. The cooling water's supply temperature must be higher than the dewpoint temperature of the room in order to prevent condensation precipitation: the air's dewpoint is normally at 14–15 °C. If there is a risk of condensation, the control vent is set to closed.

Character properties for a system with chilled beams:

- Is able to cope with large cooling requirements.
- The gaps in the supply air beam permit rapid mixture of room air over a large area and hence low air rates in the occupation zone.
- Low noise level.
- Moisture control requirements.
- Flexible regulation by being able to regulate the temperature by room or for larger zones.

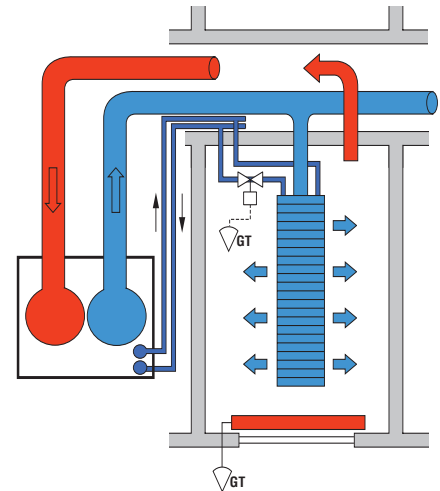

Exhaust air control

Different ways of dealing with the exhaust air in the case of variable flows

Of course, exhaust air has to be dealt with correctly.

In variable flow systems, it is important to ensure that even the exhaust air flow is controlled so that no incorrect pressure conditions occur in the building. *There are several different ways of dealing with and controlling the exhaust air:*

- Directly from every room/group of rooms (known as zoned control)
- Via transferred air terminal devices to a corridor (known as control by floor)

Of course, the various ways of dealing with exhaust air can be combined.

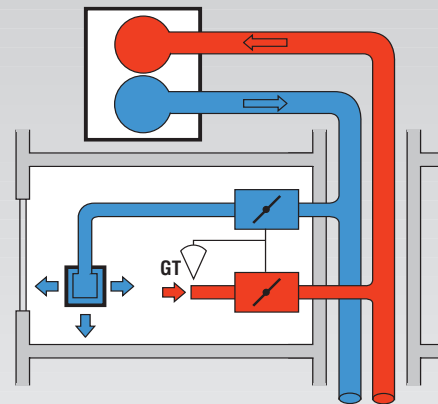

ZONED EXHAUST AIR CONTROL

Zoned exhaust air control involves exhaust air and supply air being controlled synchronously by the same sensor. Either a single room or a number of rooms with similar thermal loads can be used as regulation zones.

EXHAUST AIR CONTROL BY FLOOR OR FIRE CELL

Exhaust air control by floor means that the exhaust air from a number of regulation zones is collected via a corridor, for example (transferred air terminal devices from the rooms). The exhaust air flow is controlled by a sensor which measures the total supply air flow to the regulated zones.

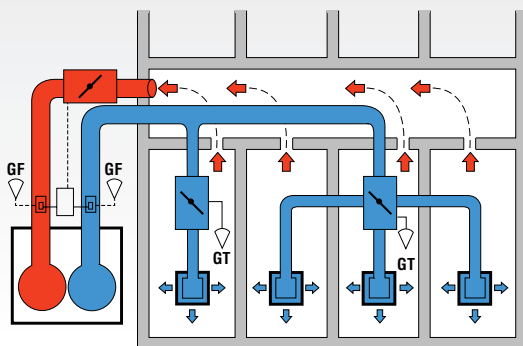

Select air transfer

Two main options

Choosing a system also involves choosing an air transfer principle. We normally differentiate between two types of air transfer in a room:

- A** — Mixed air transfer. Also known as jet air transfer.
- B** — Displaced (displacing) air transfer.

Also known as thermally controlled air transfer.

It is generally possible to design a system which works well, regardless of which air transfer principle is selected.

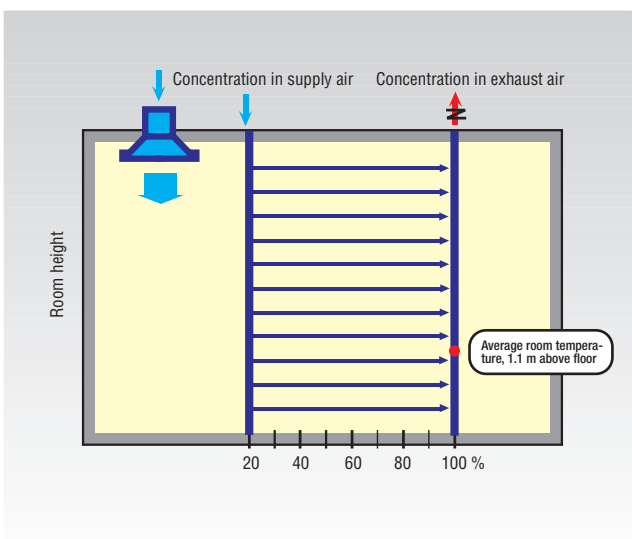
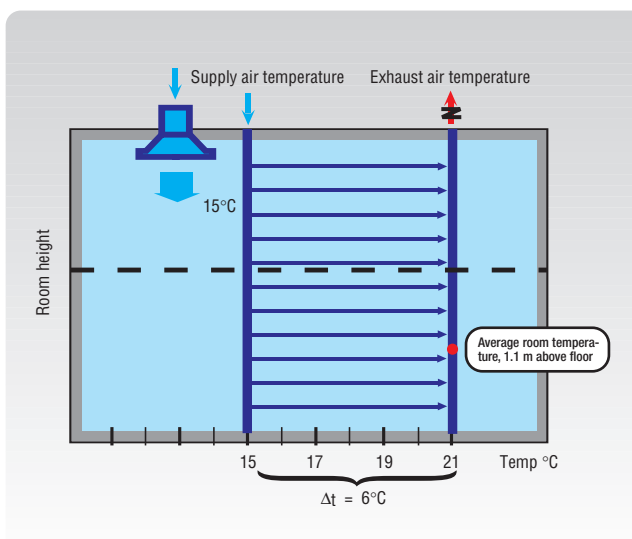
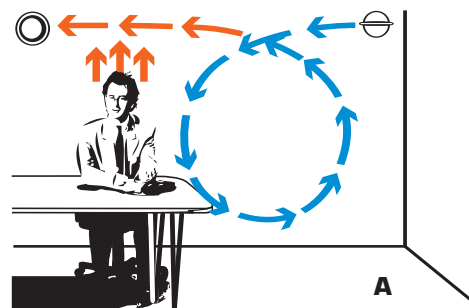

Mixed air transfer

Jet air transfer is the most common air transfer method. It is supplied in one or more high rate jets. The air jets pull ambient air with them, and their rate and direction are adjusted so that supply air and room air are mixed effectively without causing draught problems. The mixed air distributes contaminants evenly throughout the premises and the content is determined by the generated quantity and flow. Jet air transfer is relatively unsusceptible to disruption, and both heat and cooling can be added without making the temperature gradients too large.

It is common to allow the air jets to attach themselves to the ceiling or wall. This then provides a stable, circulating air flow with a small temperature gradient and little susceptibility to disruptions. On premises where a lot of cooling is required, jet air transfer may result in air rates at the floor which are too high due to the large air flows required. If jet air transfer is to be used, therefore, it is important to use devices which provide very effective mixture of the ambient air.

Displaced air transfer

In the case of displaced air transfer, the air is supplied directly to the occupation zone, with little mixture of room air. This method provides the option of good air quality and high ventilation efficiency, while at the same time the premises can be cooled at a low operating cost.

Slightly undertempered air is supplied to the premises at floor level and at low rate (0.2–0.5 m/s). The air is spread out across the floor due to the slightly higher density. Heat sources cause upward convection flows, which on their way also eject ambient air. This means that the air flow increases in the direction of flow. In the lower zone, the supply air flow is greater than the total convection flow, which means a displaced function. In the upper zone, on the other hand, the convection flow is greater than the supply air flow and so a mixture occurs there. Here, the air temperature and concentration of contaminants are higher than in the lower zone.

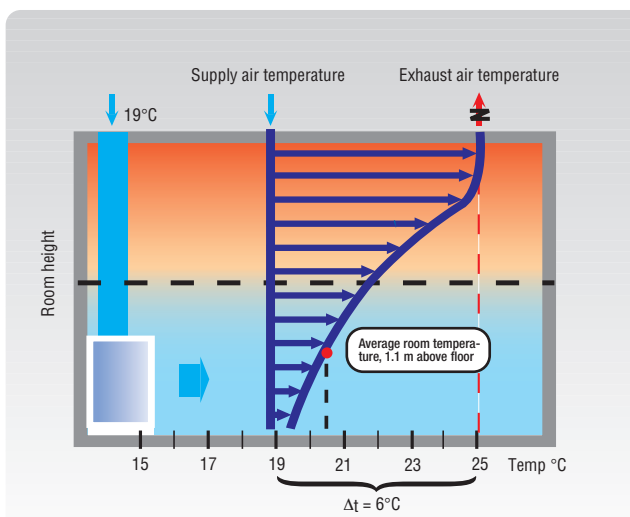
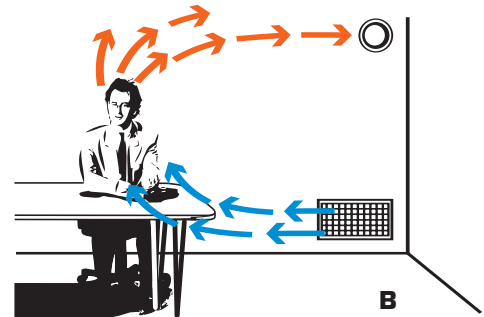

The temperature in a room with displaced air transfer rises from floor to ceiling, as shown in the illustration.

The room temperature (defined as the temperature at 1.1 m above floor level) is somewhere between the temperature of the supply air and the temperature of the exhaust air. It is worth noting that the cooling effect supplied is determined in both the displaced and the mixed cases is determined from the temperature difference between exhaust air and supply air. For a given room temperature, therefore, the supply air temperature may be higher with suppression, compared with mixed air transfer.

The slope of the temperature profile is determined by the ratio of the cooling requirement in the room to the supply air flow. The greater the cooling requirement per flow unit, the greater the slope. The profile for concentration of contaminants clearly indicates the boundary between the upper and lower zones.

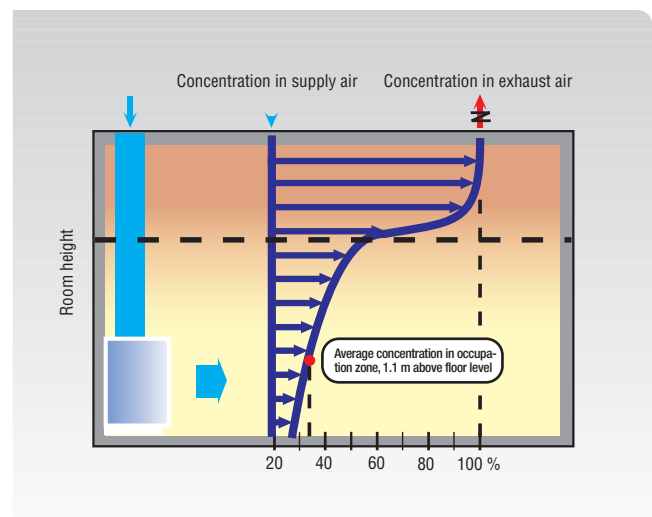

The nearest supply air device (within the comfort limit) means there is a risk of draughts for the combination of air rate and temperature, but comfort is good everywhere outside that limit. This means that a lot of air can be supplied to the premises.

The displacing function is based on the fact that the supply air temperature is lower than the room air temperature. With overtempered supply air, this immediately rises to the ceiling with a “semi-poor mixed” result.

More detailed information on the principles of air transfer can be found in the planning section of the Fläkt Woods device catalogue. The product selection programme ExSelAir is available for accurate dimensioning of data in the room.

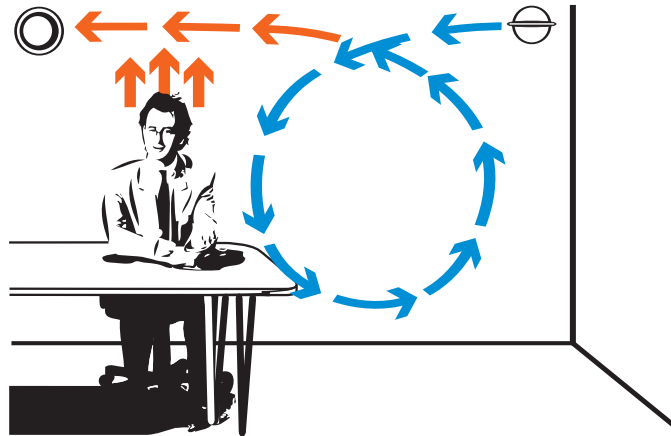

Exhaust air

In the case of mixed air transfer and overtempered supply air, the exhaust air devices must be positioned so as to prevent short-circuit of the supply air and exhaust air.

In the case of displaced air transfer, the main rule is that the exhaust air points must be placed on the ceiling.

- On large premises with high rooms, a small number of large exhaust air devices may be used
- On the other hand, large but low premises should be fitted with several exhaust air devices distributed evenly over the ceiling area in order to prevent too much horizontal transport of “used” air in the upper zone.
- If there are any dominant heat sources, it is a good idea to place exhaust air points directly above and at ceiling level.

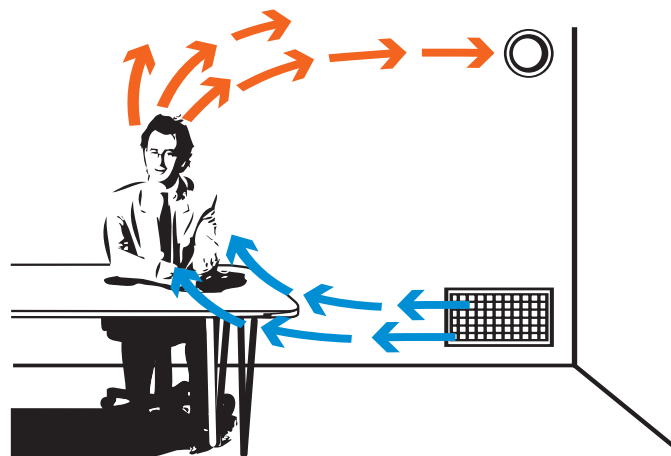

The benefits and restrictions of these methods

+ Benefits: Mixed

- Even ventilation of the entire premises, with a small temperature gradient.
- Is able to handle larger cooling effects than displaced.
- Stable flow pattern.
- Possible to heat the supply air.
- Floor free of ventilation devices.
- Large range of supply air devices with different properties.
- Traditional air transfer with broad knowledge in the industry.

— Restrictions: Mixed

- Difficult to provide high ventilation efficiency without a risk of draughts.
- Difficult to supply large air flows without a risk of draughts.
- Risk of short-circuit between supply air and exhaust air when overtempered air is supplied.
- Limited variation of the flow while maintaining the function.
- Greater capacity requirement with cooling.

+ Benefits: Displaced

- High ventilation efficiency with clean air in the occupation zone.
- Low air rates outside the comfort limit.
- Possible to supply large air flows with low noise generation.
- Less capacity requirement in the case of cooling, and hence appropriate in combination with indirect evaporative cooling.
- Flexible placement of the supply air device.
- Ceilings free of supply air ducts and supply air devices.

— Restrictions: Displaced

- This function may be disrupted by draughts from open doors.
- Less appropriate for heating.
- The devices and their comfort limit require floor space.
- Knowledge in planning is less widespread than for mixed.
- Is able to handle only moderate cooling loads at low room heights.
- Not suitable for small offices

To-do list

How to plan using this manual

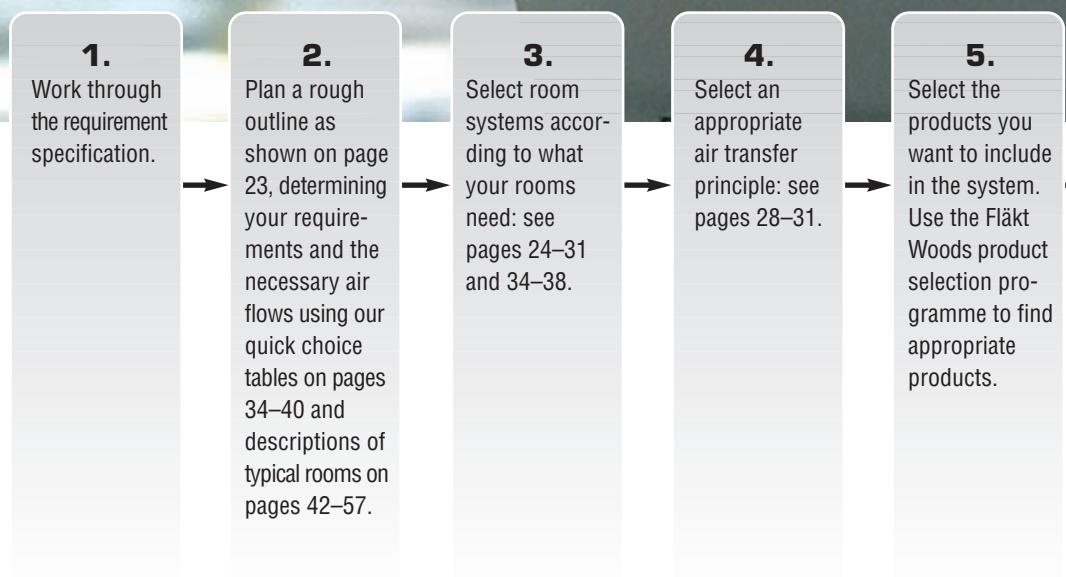

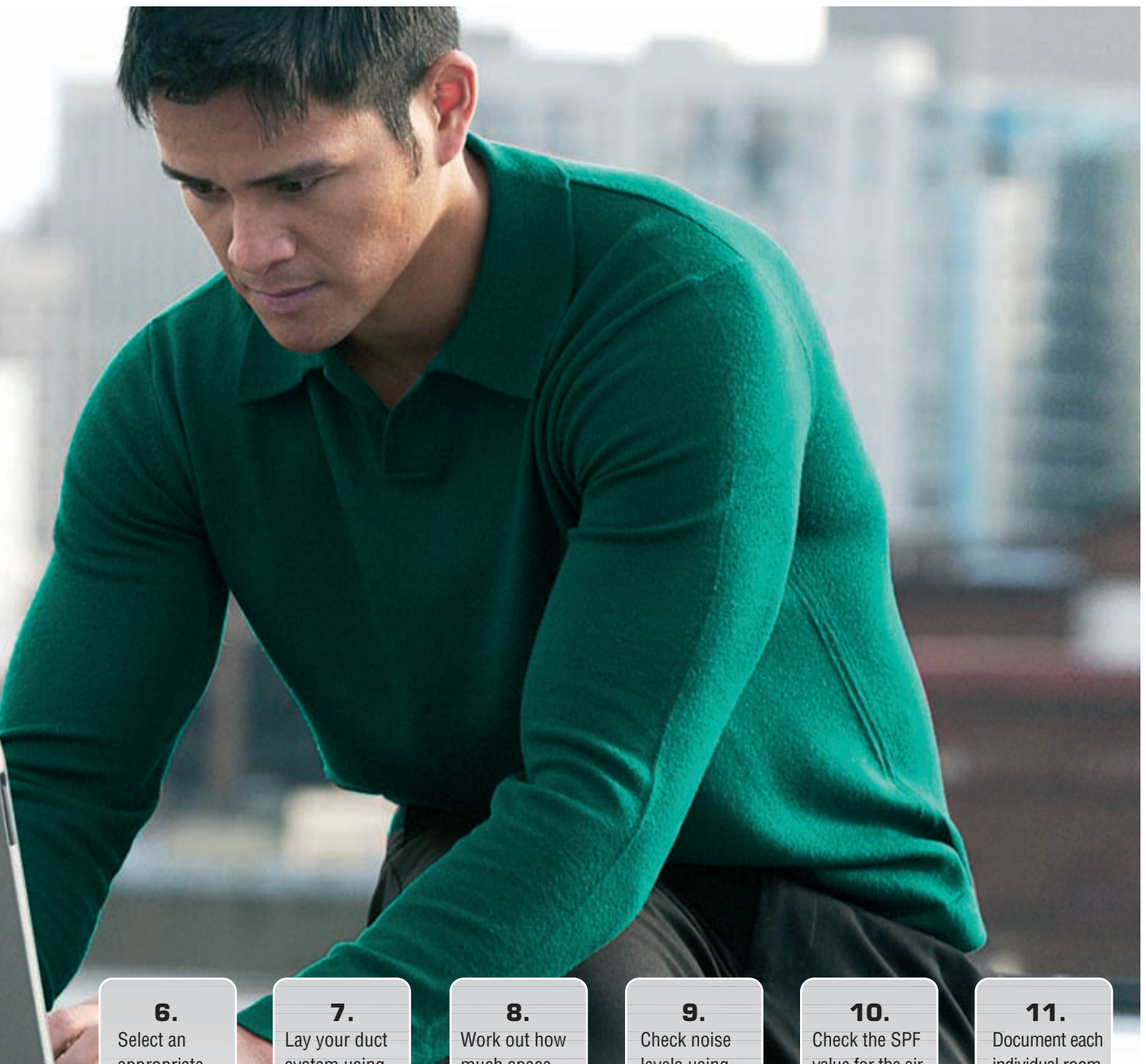

6.

Select an appropriate heat recovery unit for your air conditioning system: see page 84.

7.

Lay your duct system using the correct dimensions to be sure of having enough space for it. Use the complete system illustrations on pages 58–67 as a template.

8.

Work out how much space you require in the unit room, the weight of the unit and its electrical output and heating/cooling effect.

9.

Check noise levels using noise data from the Fläkt Woods product selection programme.

10.

Check the SPF value for the air conditioning system, and where necessary also calculate the LCC cost of the system: see pages 98–99.

11.

Document each individual room using the form on page 126.

Select a system

Quick choice tables for the following types of building

1. Select the building type that is most like the building in question, then look up the corresponding quick choice table.
2. In the quick choice table, look up the room type or types of relevance.
3. Check in the table to see what kind of typical room Fläkt Woods thinks is the most similar to the room in question.
4. Find out more about Fläkt Woods room system proposals in the manual, at the point where the typical room is described.



SHOPS/ DEPARTMENT STORES (ON PAGE 38)



HOTELS (ON PAGE 39)



LARGE OFFICES/BANKS (ON PAGE 38)



THEATRES/CINEMAS (ON PAGE 40)



RESTAURANTS (ON PAGE 39)



LIGHT INDUSTRY (ON PAGE 40)





Select a system for offices

PROPOSAL FOR TYPICAL SOLUTION

Room type	Typical room	Page	Remarks
Small office	B	48	–
Small office, stringent requirements	C	50	–
Large office	E	54	–
Conference room	D	52	–
Office storeroom	A	46	–
Canteen	E	54	–
Break room	E	54	–

An effective system will quickly pay off

The climate system in an office is extremely significant to operations. Staff will feel better and their efficiency will be enhanced if they can work in a good indoor climate. Investing in an effective system will quickly pay off.



Select a system for schools and nurseries

PROPOSAL FOR TYPICAL SOLUTION

Room type	Typical room	Page	Remarks
Lecture hall	D	52	–
Teachers' staff room	E	54	–
Library, inner	A	46	–
Storeroom	A	46	–
Gymnasium	–	–	VAV. separate system
Changing room	A	46	5 l/s, m ² floor area
Small office	B	48	–
Small office, stringent requirements	C	50	–
The canteen	E	54	5 l/s, m ² floor area
Kitchen	–	–	CAV. cooker hoods dimension the air flow

Air quality important in schools

In schools and nurseries, it has been apparent on a number of occasions that students and staff have contracted allergies and other problems due to the choice of inappropriate materials, combined with insufficient ventilation. School premises are alternately empty and full, leading to varying requirements in terms of both cooling and ventilation. School buildings also often contain gymnasiums, canteens, physics laboratories and chemistry laboratories. All in all, this demands a flexible system with different room solutions.

PROPOSAL FOR TYPICAL SOLUTION

Room type	Typical room	Page	Remarks
Loan room	E	54	–
Reading room	E	54	–
Small office	B	48	–
Small office, stringent requirements	C	50	–
Conference room	D	52	–
Book storage	A	46	–



**Select
a system
for libraries**

Noise level important

In a library, ventilation is important; not least to protect the books against damp and mould.
In reading rooms, particular care should be taken to keep the noise level down.

PROPOSAL FOR TYPICAL SOLUTION

Room type	Typical room	Page	Remarks
Care room	F	56	–
Care room	D	52	Post-heating
Examination room	D	52	–
Changing room	A	46	5 l/s, m ² floor area
Small office	B	48	–
Small office, stringent requirements	C	50	–



**Select
a system
for hospitals**

Good climate shortens care time

Hospitals are home to many different types of premises, all requiring different things from their climates. Here, you can find everything from operating theatres and intensive care rooms to offices, canteens and changing rooms. A good climate in care rooms has a positive effect on patients and helps to shorten the amount of time for which they need care. An effective climate system is required to meet the requirements of treatment rooms. With this, the foundation is laid for a good climate in offices, etc. as well, for example, with no major additional expense.



Select a system for shops and department stores

PROPOSAL FOR TYPICAL SOLUTION

Room type	Typical room	Page	Remarks
Electrical/radio/TV shops	D	52	Mixed for reasons of space
Paint shop	D	52	Mixed for reasons of space
Food shop	F	56	–
Department store, general	D	52	Mixed for reasons of space
Department store, food	F	56	–
Small office	B	48	–
Small office, stringent requirements	C	50	–

Special requirements

Special demands are made of the climate system in shops and department stores. It has to provide good air quality and prevent smells from the food department or shoe department, for example, reaching other departments. In food halls, the temperature has to be kept sufficiently low even during hot summer days. Some premises, such as electrical/lamp shops and radio/TV shops, require a high cooling effect.



Select a system for banks/ large offices

PROPOSAL FOR TYPICAL SOLUTION

Room type	Typical room	Page	Remarks
Bank premises, perimeter wall	E	54	–
Bank premises, inside	E	54	–
Small office	B	48	–
Small office, stringent requirements	C	50	–
Safety deposit vault	A	46	–
Safety deposit locker room	B/C	48/50	–

Climate important for decisions

Banks require a high-class indoor climate. In a workplace where decisions are made involving sums running into millions, people need to be able to think clearly even if the outdoor temperature is 30 °C.

PROPOSAL FOR TYPICAL SOLUTION

Room type	Typical room	Page	Remarks
Guest rooms, stringent requirements	C	50	–
Guest rooms, normal requirements	B	48	–
Conference room	D	52	–
Small office	B	48	–
Small office, stringent requirements	C	50	–
Kitchen	–	–	CAV. cooker hoods dimension the air flow
Canteen	D	52	–
Exercise room	D	52	demand controlled

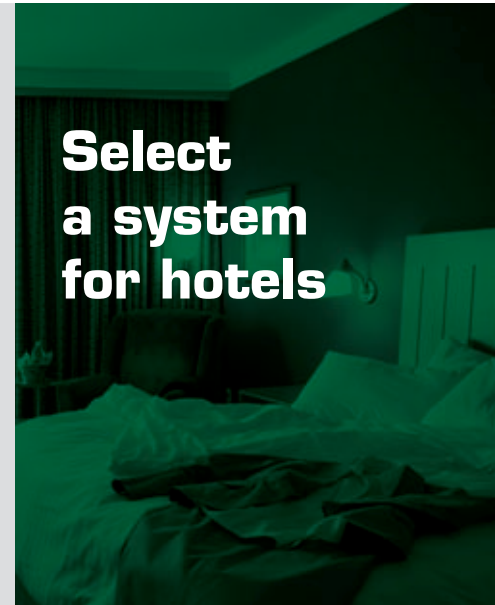

Select
a system
for hotels

Climate determines comfort

The perceived comfort of a hotel room is largely assessed according to how well the climate system does its job. It is important for the temperature to be kept down in summer so that guests can sleep well. This also requires the system to have a low noise level and be free of draughts. The ventilation air flow must be so great that the smell of smoke from a guest, for example, is able to disappear before the next guest arrives.

PROPOSAL FOR TYPICAL SOLUTION

Room type	Typical room	Page	Remarks
Canteen	E	54	5 l/s, m ² floor area
Kitchen	–	–	CAV. cooker hoods dimension the air flow
Dishwashing room	–	–	CAV. cooker hoods dimension the air flow
Fridge area	A	46	–
Dry store	A	46	–
Wine cellar	A	46	–
Small office	B	48	–
Small office, stringent requirements	C	50	–



Select
a system for
restaurants

Not just cooking smells

Restaurants include lots of different types of room. The restaurant/canteen itself requires the right ventilation and air transfer so as not to spread cooking smells. The kitchen requires hoods over hobs and griddles, but also ventilation in order to remove the excess heat.



Select a system for theatres and cinemas

PROPOSAL FOR TYPICAL SOLUTION

Room type	Typical room	Page	Remarks
Auditorium	D	52	
Machine room	D	52	
Changing room	A	46	
Dressing rooms	B	48	
Foyer	E	54	

Requirement control required

In theatres and cinemas, the climate system has to offer both a low noise level and a lack of draughts during the actual performance or film. Here, demand controlled ventilation is important. The projector in a cinema and the lights in a theatre give off a lot of heat, which has to be channelled away so as to ensure the temperature is not unbearably hot.



Select a system for light industry

PROPOSAL FOR TYPICAL SOLUTION

Room type	Typical room	Page	Remarks
Small office	B	48	–
Small office, stringent requirements	C	50	–
Workrooms	D	52	On work premises involving contaminants from processes, special measures have to be implemented in order to remove these at source.
Conference room	D	52	–
Storeroom	A	46	–
Break room	E	54	–
Changing room	A	46	–

A good climate makes people feel happier and more comfortable

In light industry, staff often work on tasks requiring precision and accuracy. They often have to take into account the heat given off by lighting and machinery. This is why the climate system is of such significance to the results.



Typical rooms

On the next few pages, we will show you six typical rooms with suggestions for appropriate indoor climate systems. These systems are a summary of Fläkt Woods' experience of planning, and we are expecting these systems to be appropriate in 90% of the environments discussed in this book. All systems can be combined to form a single system with a collective air conditioning unit which maintains a constant pressure and temperature in the supply air system.

TECHNICAL CRITERIA

The typical rooms were handled as medium-heavy during our calculations. Heavy beams with a suspended false ceiling, medium-heavy perimeter wall but otherwise lightweight structure.

U value

Structures with the following u values have been selected in the calculation. Outer wall: [W/m²,°K]0.3
Window [W/m²,°K]1.4

Infiltration

Assumed infiltration: 0.2 chs/hour for processed modules to perimeter wall.

Design outdoor state

Summer27 °C RH 50%

Operating and working hours

Operating hours: (ventilation) 00.00–24.00
Extended operating hours are assumed when calculating the room's cooling output requirement. (Normal operating hours: 07.00–18.00)
Working hours:08.00–17.00

Room temperature requirements

Two requirement levels are handled.
Moderate requirements: . . .Max. 27°C (Operating temp.)
Stringent requirements: . . .Max. 25.5°C (Operating temp.)
The air temperature in the room is taken into account in the calculation.
It is assumed that this is 1°C lower than the operating temperature in the cooling instance.

WINDOWS AND SUN PROTECTION

This calculation is executed for four levels of glass and sun protection. The following "sun factor" levels are handled: 0.40, 0.30, 0.20 and 0.10. The sun factor (g) specifies the ratio of the total transmitted solar energy through the glass combination to the total incidence of sun on the glass. Check with the glass supplier what conditions apply to specific combinations.

Examples of glass and sun protection combinations for selected sun factor (g) levels.

Sun factor (g) 0.40

Clear sun protection glass as the external glass in a insulating pane.
Alt. insulating pane with clear, low emission glass combined with an internal sun protection curtain/blind.

Sun factor (g) 0.30

Clear sun protection glass as the external glass in an insulating pane.
Alt. a smaller sun deflecting glass combined with an internal sun protection curtain/blind.

Sun factor (g) 0.20

Effective sun protection glass as the external glass in an insulating pane.
Alt. a smaller sun deflecting glass combined with an internal sun protection curtain/blind.

Sun factor (g) 0.10

To achieve a sun factor of 0.10, external sun protection, such as a blind, is generally required.
E.g. insulating pane with clear, low emission glass combined with external blind/shading awning/sun visor.

GLASS SURFACES AND INTERNAL THERMAL LOADS

Characteristic input data for selected typical rooms

Room type	Room type	Floor surface	Window area	*	Internal thermal loads						Remarks
					People		Lighting 10 W/m ²	Machinery	Total internal load		
		m ²	m ²	%	Qty.	W	W	W	W	W/m ²	
B	Small office, moderate requirements	10	2.8	40	1	100	100	150	350	35	
C	Small office, stringent requirements	10	2.8	40	1	100	100	150	350	35	
D	Config. room, stringent requirements	40	8.8	40	20	2000	400	200	2600	65	
E	Large office, stringent requirements	50	9.2	40	6	600	500	900	2000	40	
F	Care room, moderate requirements	24	2.5	20	4	400	240	0	640	27	

* % of windows, calculated on outer wall area viewed from room.

The internal load for the conference room (typical room D) has been assumed to be applied for 2 + 2 hours, with a 1-hour break between loading sessions. In terms of time, the internal load has coincided with the maximum solar load for the various perimeter walls.

Internal thermal loads in the table above specify the maximum nominal capacity for the relevant group. These effects affect the room's cooling output requirement in different ways.

In our calculation, the heat given off from people is assumed to be 100 W at a room temperature of 22°C. This capacity is reduced if the room temperature rises, and at 25°C it corresponds to approximately 77 W per person.

Heat from lighting consists of radiation on the one hand and convection on the other. The convection element directly influences the air temperature in rooms and hence also their cooling effect, while the radiation element first has to be absorbed into room surfaces and increase its temperature before any effect on the cooling output requirement takes place. The mass of the room has a major influence here.

Heat from machines is handled as pure convection and will directly affect the room's cooling output requirement.

In the event of low external supplements (solar heat), this can result in the cooling output requirement for the room being lower than the total nominal internal load.

Typical rooms



ROOM TYPE A:

STOREROOM
ARCHIVE
SIMPLE OFFICE
SAFETY DEPOSIT VAULT
COOLED ROOM

→ SEE PAGE 46



ROOM TYPE B:

SMALL OFFICE, NORMAL
REQUIREMENTS
SIMPLE HOTEL ROOMS

→ SEE PAGE 48



ROOM TYPE C:

SMALL OFFICE, STRINGENT
REQUIREMENTS
HOTEL ROOM, STRINGENT
REQUIREMENTS

→ SEE PAGE 50



ROOM TYPE D:
CONFERENCE ROOM
MEETING ROOM
AUDITORIUM
DISPLAY ROOM
SHOP
CLASSROOM

→ SEE PAGE 52



ROOM TYPE E:
LARGE OFFICE/BANK
CALL CENTRE
TEACHERS' STAFF ROOM
CANTEEN
LECTURE HALL

→ SEE PAGE 54



ROOM TYPE F:
CARE ROOM
TREATMENT ROOM

→ SEE PAGE 56

Typical room A: **Storeroom**



Description

Use	Storeroom, archive, simple office (e.g. temporary workstation)
Room area	Approx. 10 m ²
Number of persons	1 (temporarily 2)
Ventilation requirement	Must prevent ill-health
Room temperature requirement ..	No upper temperature limit. Level A (see page 10).
Cooling requirement	None (short-term presence)
Position	Inner or outer zone
Windows	Possibly
Heating requirement	Normal or none

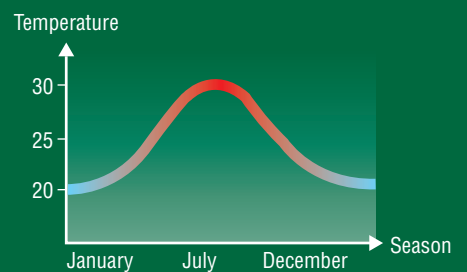

Solution

Systems Ventilation system with constant air flow (CAV)
Appropriate air flow 10 l/s (1 l/s per m² of floor area)
Air transfer Mixed
Target value for noise Max. 35 dB(A)

Results

This system is cheap and provides satisfactory air quality. But people will perceive the room temperature as problematically high over large parts of the year.



Typical room B: **Small office**



Description

Use	Office, designed for one person.
Room area	Approx. 10 m ²
Number of persons	1 (temporarily 2)
Ventilation requirement	Normal
Room temperature requirement ..	Moderate (no more than 27°C), collective temperature regulation.
Cooling requirement	Small to moderate (35 W/m ²) when good sun screening is in place.
Position	Perimeter wall
Amount of glass	40%
Heating requirement	Yes, to prevent draughts.

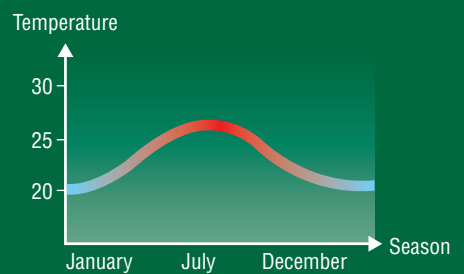

Solution

- Indoor climate systems VAV system
- Adjustment Collective regulation with small groups of similar rooms in every regulating zone (collective climate) works satisfactorily when the capacity requirement is moderate (30–40 W/m²). Remember that two in every ten people will not be happy with collective regulation. In the event of larger cooling loads, systems with individual regulation should be used — chilled beams, VAV or fan convectors; see typical room C.
- Warm-up Radiators in the case of chilled beam and VAV systems. The radiator is controlled by the outdoor temperature — outside of office hours for heating, during office hours to counter draughts. In the case of a fan convector placed in a perimeter wall, heating takes place using a heating coil built into the fan convector.
- Suitable max. air flow Approx. 30 l/s
- Suitable min. air flow 10 l/s
- Air transfer Mixed
- Target value for noise Max. 35 dB(A)

Results

A system with a climate which is perceived as considerably better than what is found in Typical room A. Flexibility with the choice of regulation zones allows this kind of system to be implemented for a moderate additional cost.

Guideline values

The total cooling output requirement of the room in W/m² of floor area in the case of different sun factor levels can be seen in the following table.

Typical room B, small office, moderate requirements				
Orientation	Sun factor (g)			
	0.40	0.30	0.20	0.10
	W/m ²	W/m ²	W/m ²	W/m ²
South	65	50	40	30
East	60	45	35	25
West	50	40	30	25
North	25			

Typical room C: **Small office, stringent requirements**



Description

Use	Office designed for one person.
Room area	Approx. 10 m ²
Number of persons	1
Ventilation requirement	Normal
Room temperature requirement ..	Stringent, individual temperature regulation.
Cooling requirement	Moderate with good sun screening (35 W/m ²).
Position	Perimeter wall
Amount of glass	40%
Heating requirement	Yes, to prevent draughts.

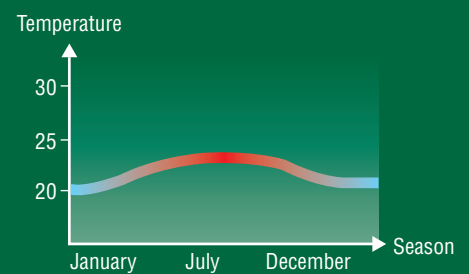

Solution

Indoor climate systems	The choice of system depends on — among other things — the cooling output requirement. Select chilled beams, fan convectors or a VAV system. See the adjacent matrix.
Adjustment	Individual regulation with temperature sensors in every room which control cooling effect supplied. The temperature sensor also controls the heating capacity supplied to the heater or radiator.
Warm-up	Radiators in chilled beam and VAV systems. The radiator is controlled by the outdoor temperature — during office hours to counter draughts, outside of office hours for heating. In the case of a fan convector placed in a perimeter wall, heating takes place using a heating coil built into the fan convector. The heating vent is controlled in sequence with the cooling vent.
Suitable max. air flow	Approx. 70 l/s. Determined by the requisite cooling effect.
Suitable min. air flow	15 l/s. Determined by the required air quality.
Air transfer	Mixed or displaced air transfer. In the latter case, low impulse devices induction should be selected.
Target value for noise	Max. 35 dB(A)

Results

Sufficient available capacity ensures flexibility in relation to the capacity requirement and makes it possible to meet individual requirements.

This makes it possible to create a system that everyone is happy with.

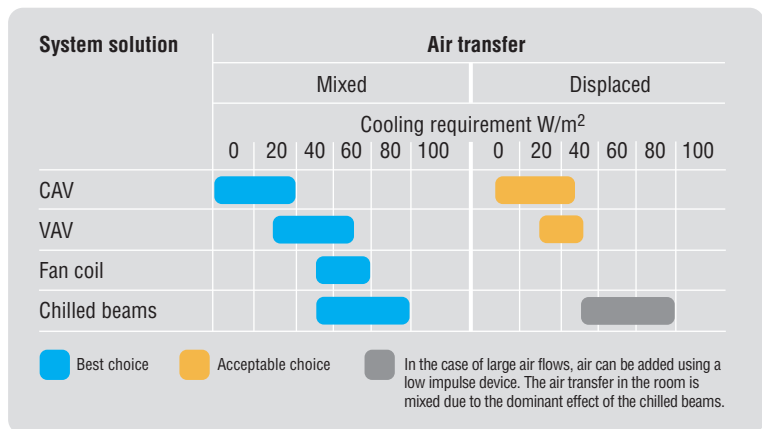

Guideline values

The total cooling output requirement of the room in W/m² of floor area in the case of different sun factor types can be seen in the following table.

Typical room C, small office, stringent requirements				
Orientation	Sun factor (g)			
	0.40 W/m ²	0.30 W/m ²	0.20 W/m ²	0.10
	W/m ²	W/m ²	W/m ²	W/m ²
South	80	65	50	40
East	70	60	45	35
West	60	50	40	35
North	35			

Typical room D: **Conference room**



Description

Use	Conference and meeting rooms, auditorium, display room, shop
Room area	40 m ²
Number of persons	5–20
Ventilation requirement	Large (periodically)
Room temperature requirement ..	Stringent (no more than 25.5°C), individual temperature regulation.
Cooling requirement	Medium to large (65 W/m ²).
Position	Perimeter wall
Amount of glass	40%
Heating requirement	Yes, at the outer zone to prevent draughts.

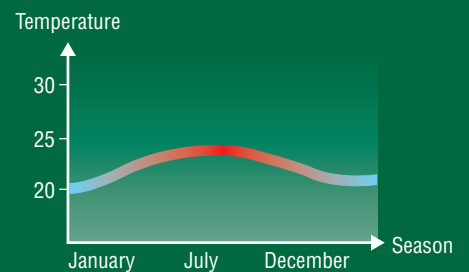

Solution

- Indoor climate systems VAV system, supplemented where appropriate with an afterheating coil in the outer zone.
- Adjustment Varying presence, periodically large ventilation requirement makes special demands of regulation. The cooling requirement controls the supply air flow between the min. and max. flow. The supply air flow can also be regulated by an air quality sensor or presence sensor. The terminal unit is then supplemented with a heating coil. The temperature of the water to the radiators is generally controlled according to the outdoor temperature in order to compensate for draughts.
- Suitable max. air flow 200 l/s, determined by requisite cooling effect.
- Suitable min. air flow Approx. 50 l/s
- Air transfer In the case of moderate cooling loads, e.g. in inner zones, displaced air transfer is used, while mixed air transfer is used in the case of large cooling loads.
- Target value for noise Max. 26 dB(A)

Guideline values

The total cooling output requirement of the room in W/m^2 of floor area in the case of different sun factor types can be seen in the following table.

Typical room D, conference room, stringent requirements				
Orientation	Sun factor (g)			
	0.40 W/m ²	0.30 W/m ²	0.20 W/m ²	0.10 W/m ²
South	85	75	65	55
East	80	70	60	50
West	75	70	60	50
North	50			
Inner zone	45			

Typical room E: **Large office**



Description

Use	Fairly large office room with a lot of people and a lot of heatgenerating machines
Room area	50 m ²
Number of persons	10–15
Ventilation requirement	Normal
Room temperature requirement ..	Stringent (no more than 25.5°C), individual temperature regulation.
Cooling requirement	Medium to large (40–80 W/m ²).
Position	Perimeter wall
Amount of glass	40%
Heating requirement	Yes, at the outer zone to prevent draughts.

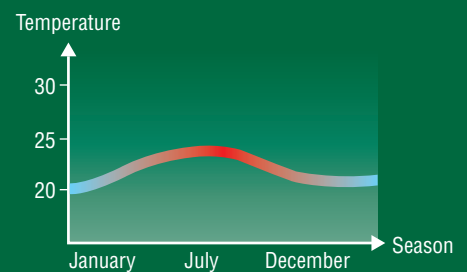

Solution

- Indoor climate systems Chilled beams and constant air flow.
 Given the large cooling requirement, it is appropriate to use chilled beams with supply air distributed evenly across the ceiling area. The total cooling effect for the room consists of basic cooling by means of the air supplied and a larger, controllable element from the cooling coil of the chilled beam.
- Adjustment Room temperature sensor and control vents regulate the water flow through the chilled beams' coils.
 The radiators are controlled either in sequence using the chilled beams or by the outdoor temperature in order to compensate for draughts.
- Appropriate air flow 10 l/s and person, meeting normal air quality requirements.
- Air transfer Mixed air transfer.
- Target value for noise Max. 40 dB(A)

Guideline values

The total cooling output requirement of the room in W/m² of floor area in the case of different sun factor types can be seen in the following table.

Typical room E, large office, stringent requirements

Orientation	Sun factor (g)			
	0.40 W/m ²	0.30 W/m ²	0.20 W/m ²	0.10 W/m ²
South	65	55	45	40
East	60	50	45	35
West	55	50	45	40
North	35			

Typical room F: **Care room**



Description

Use	Care room at hospital
Room area	Approx. 24 m ²
Number of persons	4
Ventilation requirement	Stringent
Room temperature requirement ..	Moderate (not over 27°C), collective temperature regulation.
Cooling requirement	Small (15–30 W/m ²).
Position	Perimeter wall
Amount of glass	20%
Heating requirement	Yes, to prevent draughts.

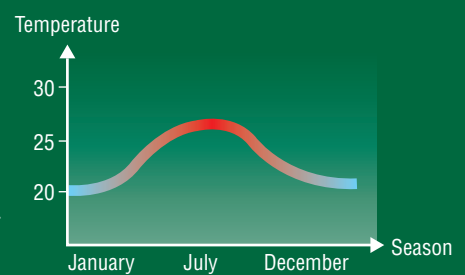

Solution

- Indoor climate systems CAV system with afterheating; in the case of greater cooling requirements, a VAV system is selected.
- Adjustment Individual or collective regulation of room temperature, depending on the scope of the cooling requirement. The supply temperature to any radiator system is controlled according to the outdoor temperature.
- Appropriate air flow Min. 10 l/s and person, determined by the required air quality.
- Air transfer Displaced, low impulse device.
- Target value for noise Max. 35 dB(A)

Results

When the ventilation requirement is sufficiently great to maintain the entire cooling effect, a good indoor climate is achieved at a low cost. In the event of major demands in respect of temperature, or if there is a great cooling requirement, the air flow must be increased and controlled by demand.

Guideline values

The total cooling output requirement of the room in W/m² of floor area in the case of different sun screening types can be seen in the following table.

Typical room F, care room, moderate requirements

Orientation	Sun factor (g)			
	0.40 W/m ²	0.30 W/m ²	0.20 W/m ²	0.10 W/m ²
South	30	25	20	15
East	25	20	15	15
West	20	20	15	15
North	15			

Note

The window area in this kind of typical room is moderate. If it is increased, the air flow must also be increased in order to handle the cooling effect.

Tips on selecting systems and products

A few examples of systems are shown on the next few pages:

- A constant flow system: *see pages 60–61*
- A variable flow system: *see pages 62–63*
- A system using waterborne cooling: *see pages 64–65*
- A combination system: *see pages 66–67*

The norm in most buildings is a combination system where room systems are selected according to the requirements of the individual rooms. Examples of “clean” systems exist in the first instance so that the various basic systems (CAV, VAV, fan convector, chilled beams) can be described clearly. In these examples, we will give you tips on pressure, sensor placement, duct dimensions and duct rates, noise attenuation, etc.

Explanations of terms

The system outlines include the following terms and abbreviations:

e Duct rate GT Temperature sensor
 Δp_{tot} Total pressure drop GP Pressure sensor



A constant flow system

Ventilation only

This section describes a pure constant flow system. The aim is primarily to show how the constant flow elements of a system are built up, and hence to facilitate planning of a combination system.

UNIT

Several unit sizes can generally be selected for a given air flow. A larger unit size means a reduction in operating costs. The unit should be fitted with a rotary heat exchanger with a hygroscopic rotor, which reduces drying out over the cold season. It must be possible to regulate the rate of the rotor as this doubles the rotor's energy saving. Therefore, it must be possible to regulate and dimension the air heater effectively just as an afterheater, not as a replacement for the heat recovery unit. See also the instructions for each unit in the Fläkt Woods unit catalogues.

FLOW MEASUREMENT AND ADJUSTMENT

It must be possible to measure both supply air and exhaust air flow in an air conditioning unit. This is most appropriately done using a fixed measuring device in the inlet for the fan in question. The duct system is also provided with fixed measuring devices which facilitate adjustment to the correct air flows in the respective ducts. The method error of the measuring devices should be no more than $\pm 5-7\%$. It is also possible to select products which can be cleared of contamination using mechanical tools (brushes and suchlike).

PRESSURE LEVELS AND PRESSURE DROP CALCULATION

If pressure levels and duct dimensions are selected as shown in the illustration, you do not normally need to carry out any pressure drop calculation below the dashed line in the illustration. Note that in the case of supply air, the device nearest to the

unit is the dimensioning device with regard to pressure drop; in the case of exhaust air, the device furthest away is the dimensioning device. In the case of tall buildings, it may be appropriate to further increase the pressure levels in the main ducts in order to counter the effect of thermal lift.

REGULATION

In systems with more than one regulation zone, supply air regulation usually works best. The supply air temperature at sensor GT1 should never exceed 17°C in the case of comfort systems. In a system without cooling, this means that the rotary heat exchanger or air heating never has to be activated if the supply air temperature exceeds 17°C . For units with integrated control and regulation equipment, see also the Fläkt Woods unit catalogues.

NOISE ATTENUATION

Normally silencers are required after the supply air fan and after dampers. An accurate calculation (see *Noise in the air conditioning system* on page 113) determines whether any dampers can be dispensed with. *Note:* A "large" unit reduces the need for noise attenuation and also reduces energy consumption.

IMPORTANT!

There are instructions for every unit on how noise attenuation is to be arranged. These instructions have to be followed carefully. Incorrect connection of silencers can cost up to 200 Pa in unplanned pressure drop, and also cause a function failure.

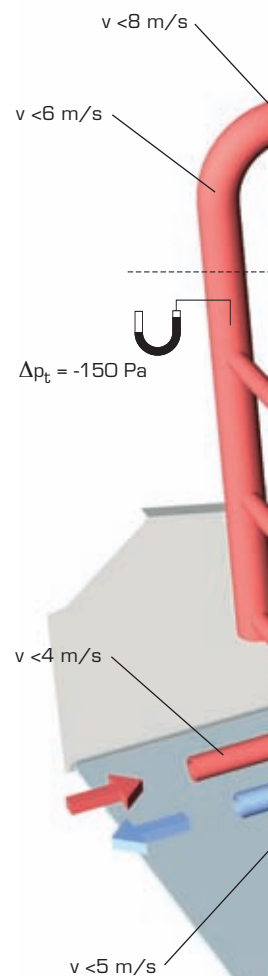

TOILET AIR

The toilets are best ventilated with an exhaust air flow of at least 15 l/s.

SHUT-OFF DAMPER

Placed near outer walls to keep cold air to the unit to a minimum.

OUTER WALL GRILLE OR EXTRACT AIR HOOD

Placed so as to avoid a short-circuit.

OUTER WALL GRILLE AT AIR INTAKE

Ideally placed facing north and so that the effect of hot roofs is eliminated. Avoid positioning facing traffic routes. The outdoor air intake and extract air should be formulated in such a manner as to prevent a short-circuit.

AIR DEVICES

All Fläkt Woods supply air devices for comfort ventilation can ideally be dimensioned at $p_{tot} = 50$ Pa. Control vents should be dimensioned for max. 100 Pa.

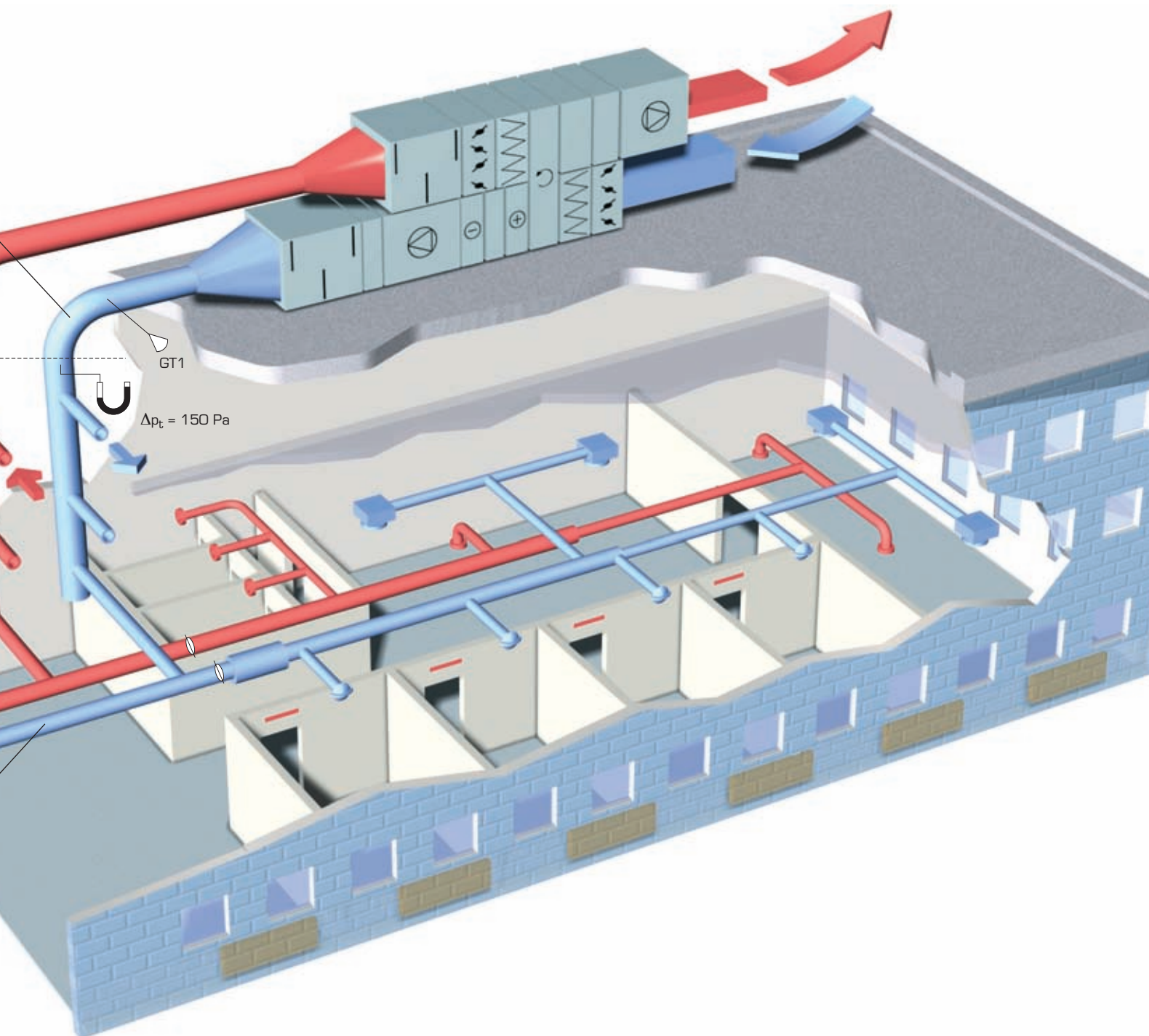

A variable flow system

Airborne cooling: VAV system

This section describes a pure VAV system. The aim is primarily to show how the VAV elements in a system are built up, and hence to facilitate planning of a combination system.

UNIT

The job of this unit is to keep the supply air temperature constant and to keep the pressure levels constant in the supply air and exhaust air ducts. To achieve a constant supply air temperature, a rotary heat exchanger with rate regulation is selected in the first instance. The air heater must not be overdimensioned as this will make it difficult to regulate. As the rotor is very efficient at small air flows, air heaters in practice will give off small amounts of heat, if any at all. Select an air cooler which is easy to regulate, such as a water-cooled air cooler. However, nowadays there are also several different ways regulate cooling using evaporating refrigerants. Pressure regulation of fans reduces energy consumption and keeps the noise level low. Both B wheel fans and plug fans can be regulated using frequency inverters. The supply air temperature at GT1 is generally constant all year round: approx. 13–14°C for mixed and 18–19°C for displaced air transfer. The air to the supply air devices is then approx. 1 degree higher due to heating in the duct system. As the unit's mean annual air flow is often just half of the projected maximum air flow, the unit can be selected so that it just handles the maximum air flow.

REGULATION OF EXHAUST AIR

To ensure that troublesome pressure differences do not occur in the building, the exhaust air flow should be controlled in parallel with the supply air on every floor. This arrangement consists of flow sensor units in the supply air and exhaust air

ducts, and a specially equipped VAV unit in the exhaust air. If you cannot accept excess air to the corridor, you can use parallel control of supply air and exhaust air to the same regulation zone. See also page 25.

AIR DEVICES

All air devices must operate at both maximum and minimum flow. When selecting devices, it is important to also take into account pressure drop, throw and noise.

VAV UNITS

Important things to consider when selecting VAV units:

- The regulation function must be independent of pressure changes in the duct system.
- The units must function irrespective of the installation direction. They must have a flow measurement function independent of the regulation equipment.

DUCT DIMENSIONING/PRESSURE LEVELS

Supply air — Dimensioning method: the 30% method.

Devices in the “worst” positions: Generally the device nearest to the supply air fan.

Pressure level: Approx. 150 Pa, i.e. the requisite static pressure at pressure sensor GP1.

Exhaust air — Dimensioning method:

Constant pressure drop per length unit.

Devices in the “worst” positions: Always the device furthest away from the exhaust air fan.

Pressure level: Approx. 150 Pa, i.e. the requisite static pressure at pressure sensor GP2.

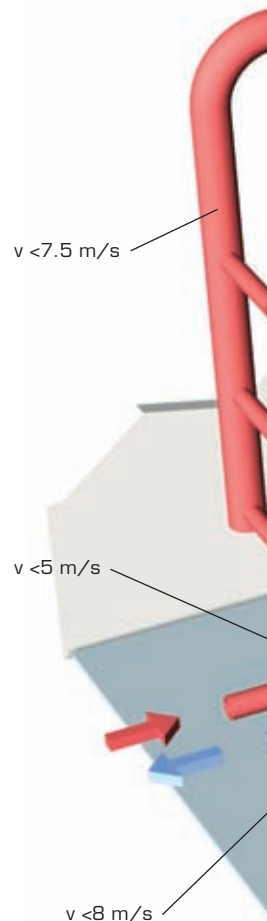

DUCT RATES

Note that the specified rates are applicable at maximum air flow. At the mean annual flow, which is often about half of the maximum flow, therefore, the air rate will be just half of the specified air rate. Of course, it is not incorrect to dimension for lower duct rates.

ADJUSTMENT

It is easy to adjust a VAV system. Check the function of the units and that the air conditioning unit is able to handle the projected maximum flow. If the pressure sensors are positioned correctly, the units nearest to the pressure sensors are almost fully open at the projected maximum flow.

THE 30% METHOD

Dimensioning in accordance with the 30% rule means that the main duct for the supply air must have a constant area up to the branch where the tapped flow constitutes more than 30 % of the flow in the main duct before the branch duct. After this branch duct, the main duct is reduced by one dimension stage. The main duct is reduced after this by one dimension stage after each subsequent branch.

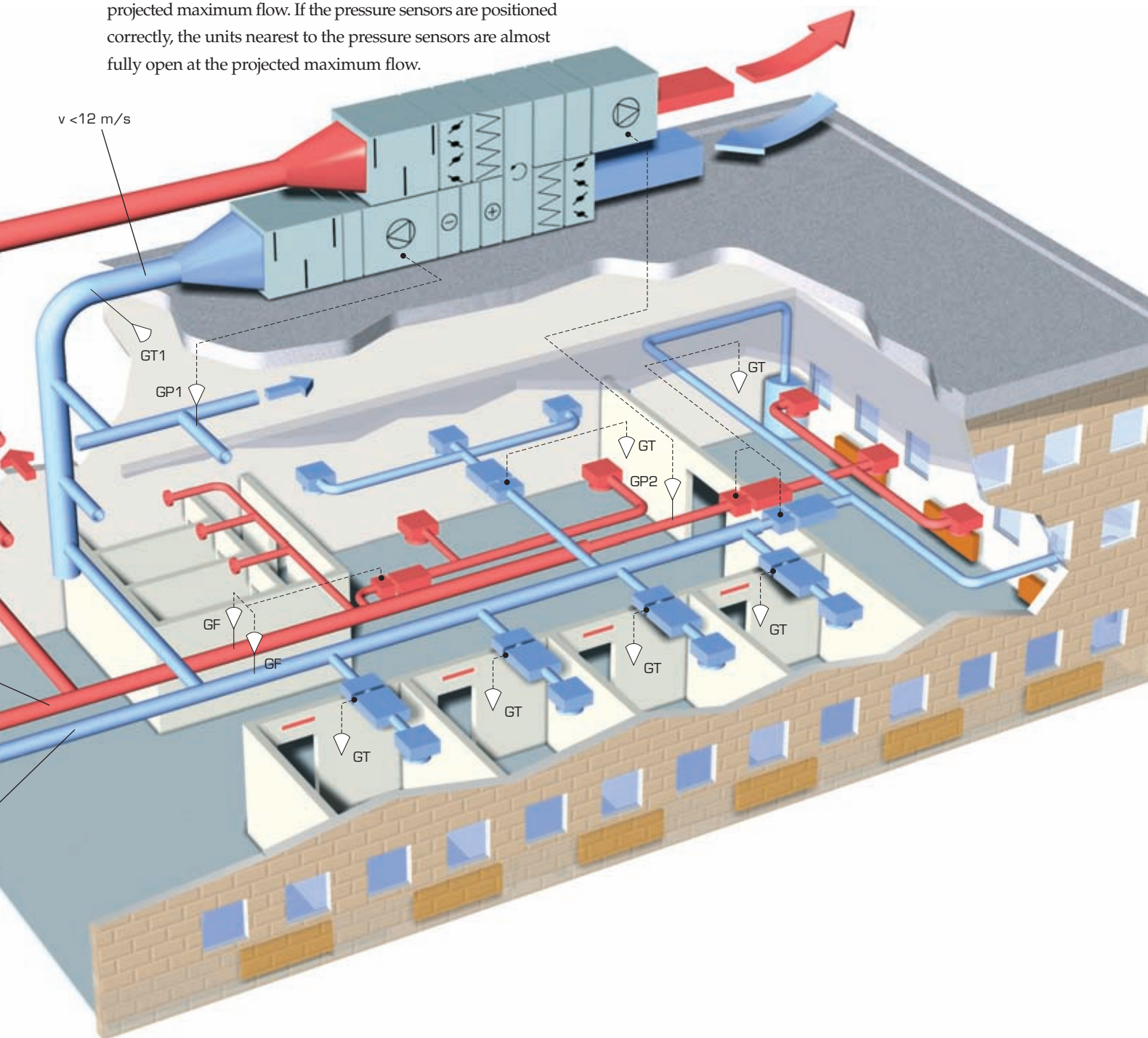

A system using waterborne cooling

Separate ventilation and cooling

This section describes a system with pure waterborne cooling. Its main aim is to show how the waterborne elements in a system are built up, and hence to facilitate the planning of a combination system.

AIR SIDE

See pages 60–61 for more information on:

- Duct rates
- Noise attenuation
- Flow measurement/adjustment

UNIT WITH WATER COUPLING

The simplest way of implementing this system is in a manner which does not permit condensation in the room units. This means that the cold water at sensor GT2 must not be colder than 14°C. At the same time, the supply air must be relatively dry. This is achieved by cooling the supply air to 17°C or lower (sensor GT1).

Note that the output of the cooling machine increases markedly if the cold water temperature increases from its normal 6°C. This will allow you to select a smaller cooling machine. If the cold water temperature is increased, this must be taken into account when the unit's air cooler is dimensioned.

ALTERNATIVE UNIT

The principal unit's cooling shunt can be offset, particularly when Fläkt Woods low water consumption fan convectors are used. The air heater can then also be replaced by a heater in the water circuit. In addition, energy is saved by means of free cooling and by means of a reduced electrical output to the cooling machine thanks to a high cold water temperature.

FAN CONVECTORS

Important things to bear in mind when selecting products:

- Low noise level
- Small requisite water flow
- Sufficiently high air impulse so that sufficient mixing is achieved

Fläkt Woods fan convectors meet these requirements. Fan convectors are normally dimensioned at the minimum fan speed. This means a large power reserve when you want to cool individual rooms quickly.

CHILLED BEAMS

Important things to bear in mind when selecting products:

- Low noise level
- High cooling effect
- Flexible length in respect of capacity and adaptation to room conditions
- Simple, fast installation
- Chilled beam easy to clean

The water temperature to the chilled beams must be above the dewpoint of the room air. Normally 14–15°C. In the case of moderate heating requirements, the beam can be provided with heating coils on the bottom plate. This gives a combination of radiation and convection.

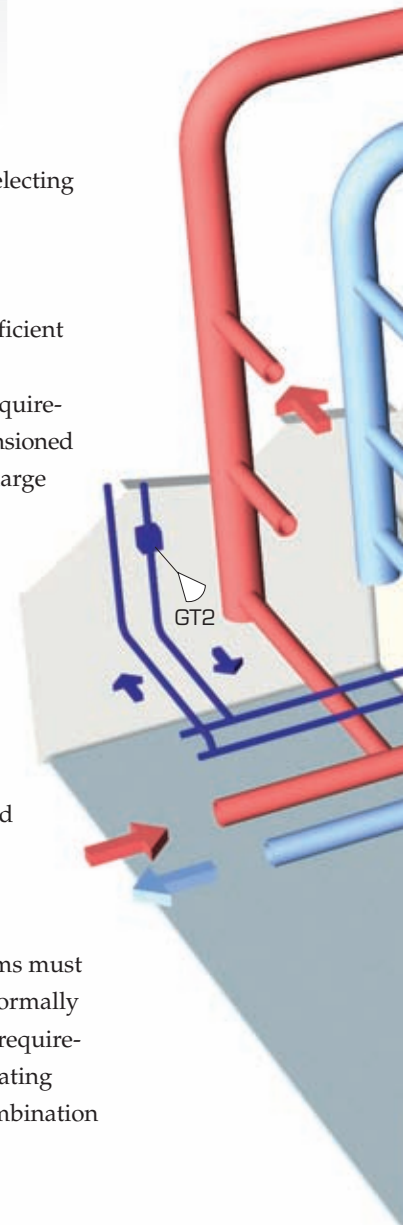

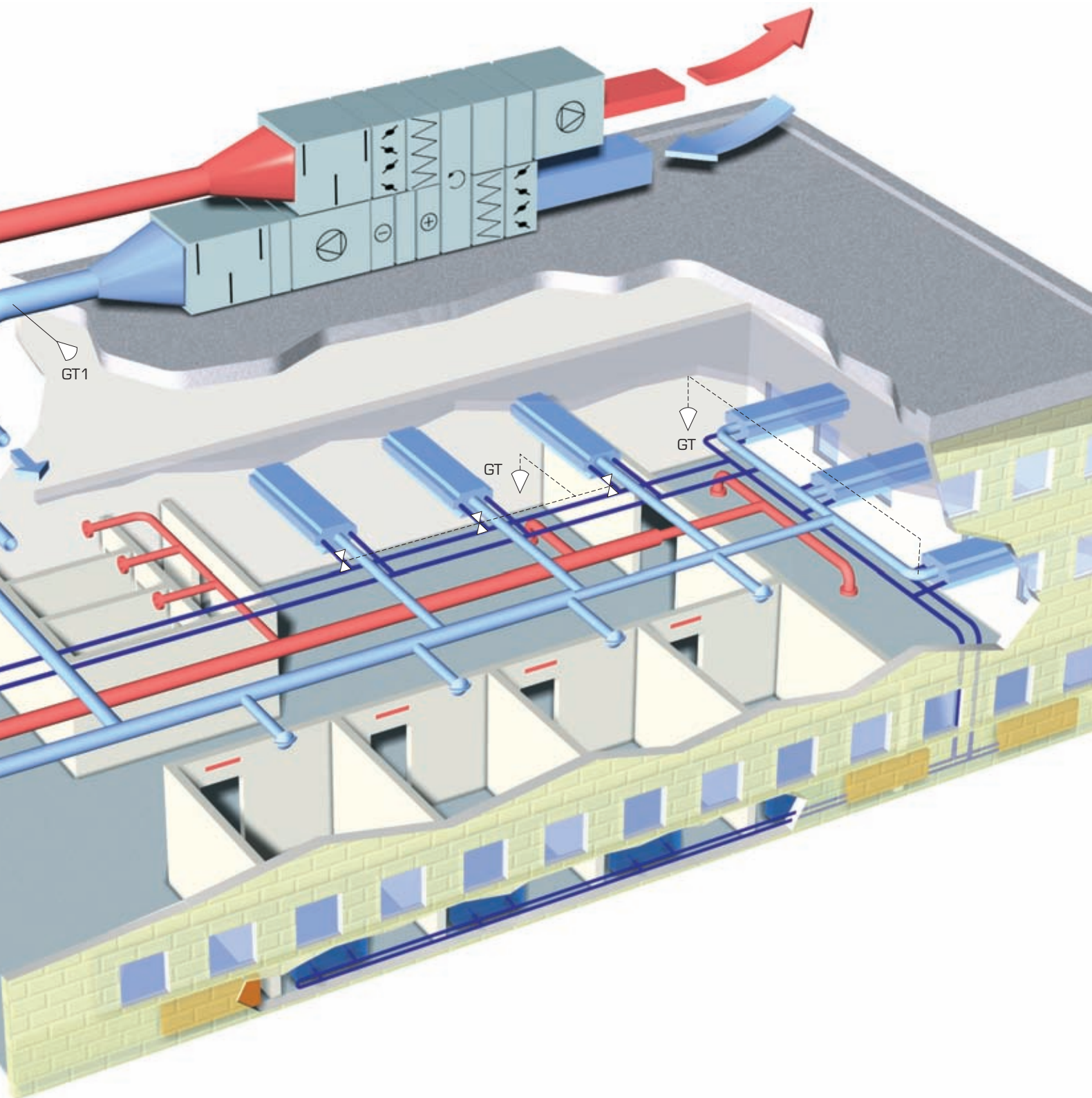

One combination system

Constant and variable flow

Most modern systems will be combination systems where constant flow is used in some rooms, and variable flow in others.

AIR CONDITIONING UNIT

See pages 62–63, “A variable flow system”.

PRESSURE LEVELS AND PRESSURE DROP CALCULATION

See pages 60–61.

DUCTS

Two cases:

- 1 Constant flow elements are divided using an ordinary adjustment damper. The duct rates are selected as shown in the adjacent illustration. Air devices connected directly to floor ducts without flow variators must be selected for a total pressure drop of 150 Pa. In many cases, this means that supply air devices have to be connected with duct dampers and silencers.
- 2 Constant flow elements are divided using flow variators. The same duct rates as with the variable flow system. See pages 62–63.

ADJUSTMENT DAMPER

No adjustment dampers are to be placed before units in variable flow systems. Ordinary adjustment dampers are sufficient for constant flow systems. With correctly positioned pressure sensors, the pressure level is so even that the air flow is constant even without flow variators or constant flow devices. Mechanical constant flow devices also often increase the pressure level unnecessarily.

VAV — VARIABLE FLOW SYSTEM

Find out more about variable flow systems on pages 62–63 and pages 24–25.

FAN CONVECTOR AND CHILLED BEAMS

Find out more about waterborne cooling on pages 64–65 and pages 24–25.

CAV — CONSTANT FLOW SYSTEM

Find out more about constant flow systems on pages 60–61 and pages 24–25.

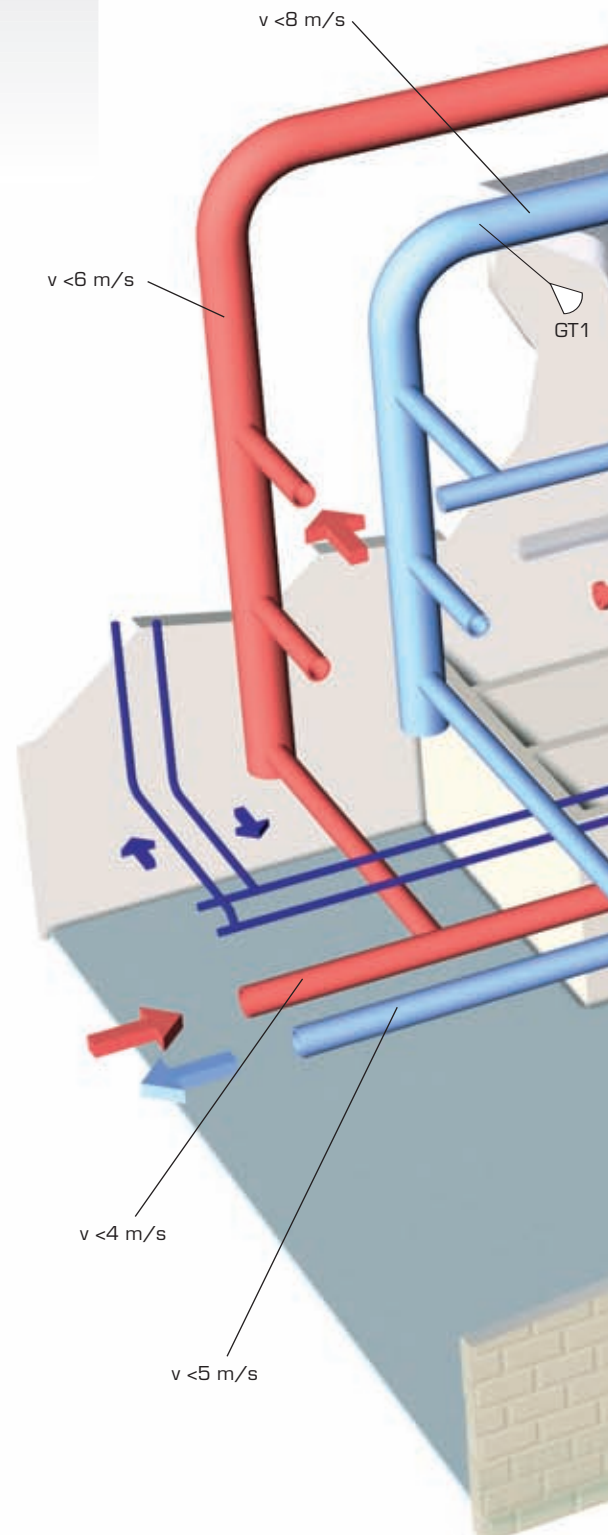

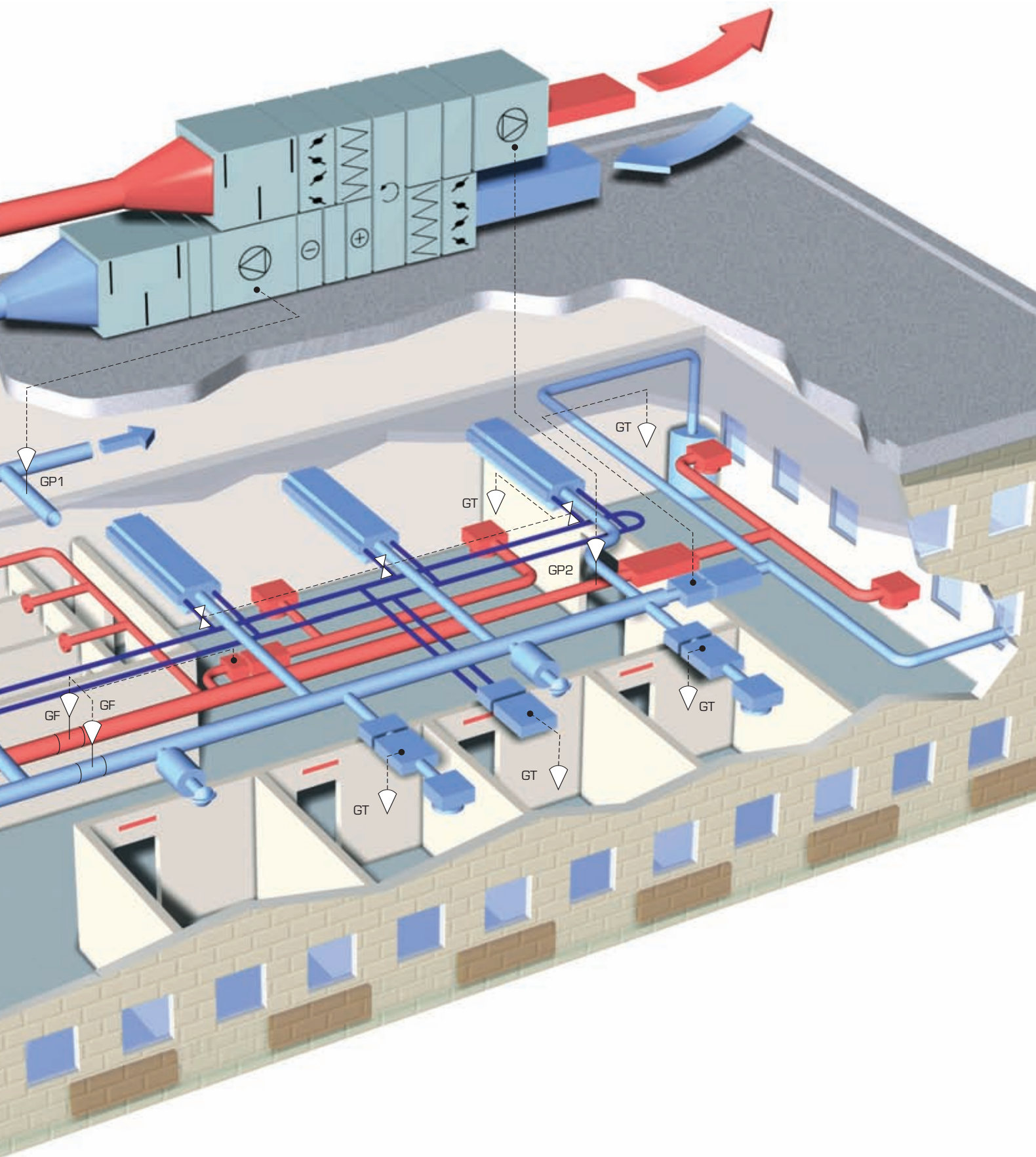



Good indoor air is absolutely vital

A grown person eats approx. 1 kg, drinks approx. 3 l and breathes approx. 25 000 litres of air a day. Living in Sweden, we also spend 90 % of our time indoors, and half of that time we are at home. Despite this, we are incredibly careful about what we eat and drink, but not with what we inhale. Surely everything we eat, drink and inhale should be classified as a “food”?

If you ask this question, the vast majority of people know that air is important to our health, but even so — we take it for granted far too often. The air is just there, and we assume it is good enough. But unfortunately, this is the case far too rarely.

The Värmland trial — the world’s biggest indoor air research project, indicates that many Swedish homes do not even meet the low demands of the authorities of 0.5 air replacements per hour. An “air change” means that the

old air is swapped for fresh new air. The trial shows a clear link between a low air change in the home and — for instance — asthma and allergies in children. According to the Swedish Institute of Radiation Safety, 500 people die every year because of stale indoor air.

Mist on the windows, problems with getting rid of damp in bathrooms, and fatigue or irritated airways are just a few signs of poor ventilation. Regardless of which problems you have, it is important for you to regularly review your ventilation at home. The exhaust air vents in the bathroom, for example, are checked by placing a piece of kitchen paper in front of the extractor. The paper should remain in place.

A fully functional ventilation system takes in clean, fresh air and transports out stale old air, moisture and smells. This makes the air healthier to breathe, and you and your family will quite simply feel better.

Home ventilation

The most complete ventilation system is known as balanced ventilation, an FTX system. This is a fan controlled supply and exhaust air system with heat recovery which gives you full control over the quantity of fresh air supplied to your home. This is a stable, flexible and cost effective system.

When you invest in an FTX system, your house will be fitted with a duct system (these ducts are already laid in many buildings) which transports used air out and supplies new fresh air. But before the heated indoor air (exhaust air) is sent out, it passes a heat recovery unit which uses the energy in the exhaust air to heat the cold incoming supply air. This will help you to save energy while at the same time improving your indoor air.

The supply air vents are placed in living rooms and bedrooms, while the exhaust air vents are placed in bathrooms, toilets and utility rooms. This means that the air comes in at the point where it ought to, and your FTX system makes sure that the fresh outdoor air supplied is very close to room temperature. This gives you a very pleasant air exchange and great comfort, with a minimal risk of draughts. The balanced ventilation systems also have effective filters which remove the dust and pollen in the outdoor air.

With an FTX system, you will recover 50–80% of the heat you need to supply to the air, which means a saving of 5 000–7 000 kWh a year for a normally sized house, terrace or apartment. Another important parameter is that the ventilation is separate from the heating, which means that you can freely select a source of heat both now and in the future.

Certainly, balanced ventilation requires separate ducts, but servicing and maintenance costs are low thanks to the fact that there are few moving parts. This means that you will soon make your money back. Trials show that the time for return on investment in an FTX system is 3-5 years. An investment which all property owners should make. And if not for the sake of profitability, then for the sake of health.

The National Board of Health and Welfare and the National Board of Housing, Building and Planning say that the air turnover must be 0.5 times per hour — which means that much of the air has been replaced after two hours. Many homes in Sweden fall well below this requirement.

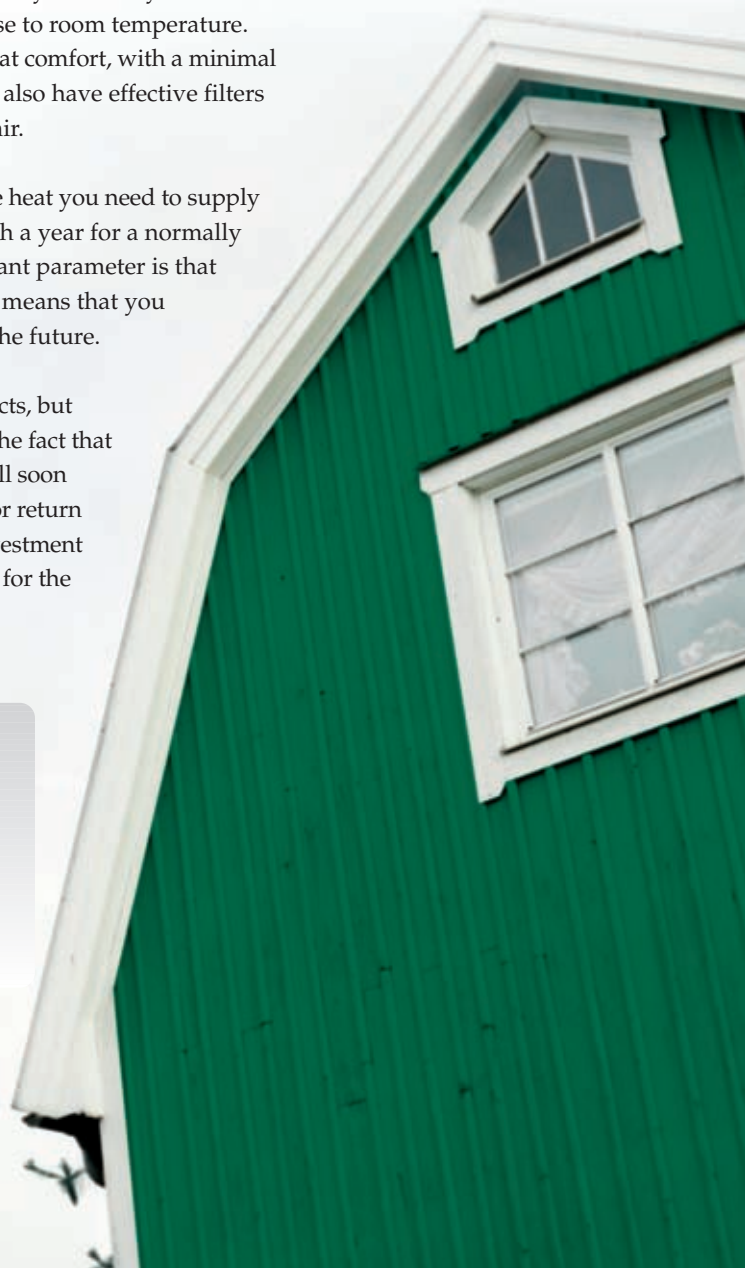

Minimaster 0–155 m²

MINIMASTER SYSTEM IN BRIEF

- Kitchen based unit
- Heated supply air is distributed to all rooms
- No cold draughts
- Efficient energy recovery
- Allows the effective filtration of outdoor air and exhaust air
- Ventilation unit RDKG has high recovery capacity, up to 66%
- Ventilation unit RDKR has rotary heat exchangers
- RDKR up to 83% heat recovery capacity
- Both RDKG and RDKR have low electricity consumption

For houses and apartments over one or two floors, 0–155 m², we recommend Minimaster, balanced ventilation with heat recovery. As a principal unit, we use the kitchen based ventilation unit RDKG or RDKR with associated cooker hood CPDC or CPDJ. Here, in other words, the unit is linked with the kitchen fan. If you do not want the ventilation to be linked with the kitchen fan, you can just as well select a wall mounted unit which is placed in the utility room, for example; and in this case, the system is known as Minivent.

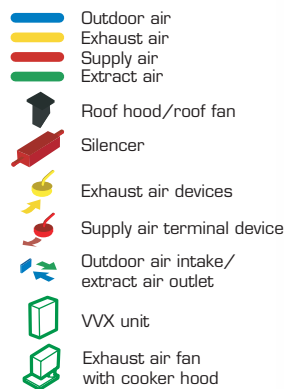

Minivent 0–155 m²

If you want a separate kitchen fan and to be able to select a specific cooker hood, you should invest in the Minivent. The only difference between the Minimaster and the Minivent is that the latter is not placed in the kitchen. Instead, the Minivent can ideally be placed in a warm area such as a utility room or storeroom. An RDKG or RDKR ventilation unit with built-in control unit is used as the principal unit in the system. Both the Minimaster and Minivent are very effective ventilation solutions for houses and apartments, as well as for smaller premises over one or two floors of 0–155 m².

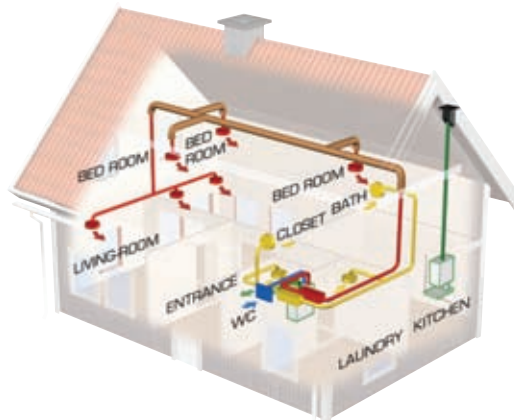
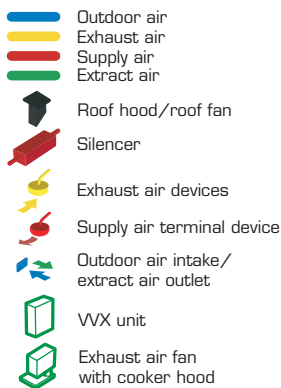

MINIVENT SYSTEM IN BRIEF

- Placed in a warm area in homes or on premises, such as in a utility room or storeroom
- Heated supply air is distributed to all rooms
- No cold draughts
- Efficient energy recovery
- Allows the effective filtration of outdoor air and exhaust air
- Ventilation unit RDKG has high recovery capacity, up to 66%
- Ventilation unit RDKR has rotary heat exchangers
- RDKR up to 83% heat recovery capacity
- Both RDKG and RDKR have low electricity consumption

Rexovent 156–280 m²

REXOVENT SYSTEM IN BRIEF

- Insulated on the outside for placement in cold areas, such as attics
- Preheated supply air is distributed to all spaces that are in use more than temporarily.
- No cold draughts
- Efficient energy recovery
- Ventilation unit RDAB 130 W
- Has a new, higher capacity filter solution

For houses and smaller one or two-floor buildings of 156–280 m², we recommend Rexovent, balanced ventilation with heat recovery. The ventilation unit RDAB, with its fan size of 130 W, is used as a principal unit and can be placed in a cold area such as in an attic. Here, too, you have a separate kitchen fan and can choose whatever cooker hood you prefer. The system provides effective ventilation for all rooms and recycles the heat in the used air leaving the house. In addition, it contains a number of components customised for the system.

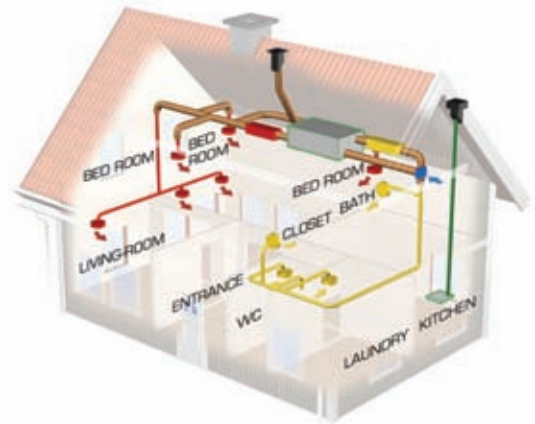
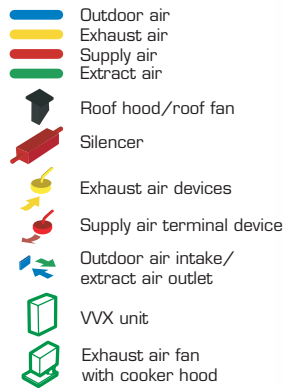

Rexovent Turbo 281–370 m²

For one and two-floor apartment buildings of 281–370 m², we recommend Rexovent Turbo, balanced ventilation with heat recovery. This system is especially suitable for use in apartment buildings where a common unit is required for stairwells, offices, childcare centres, small industrial premises or storerooms. Rexovent Turbo is built up around the ventilation unit RDAB 250 W, which is placed in a cold area such as an attic. The system provides effective ventilation and recycles the heat in the used air leaving the building.

REXOVENT TURBO SYSTEM IN BRIEF

- Insulated on the outside for placement in cold areas, such as attics
- Preheated supply air is distributed to all spaces that are in use more than temporarily.
- No cold draughts
- Efficient energy recovery
- Ventilation unit RDAB 250 W
- Has a new, higher capacity filter solution

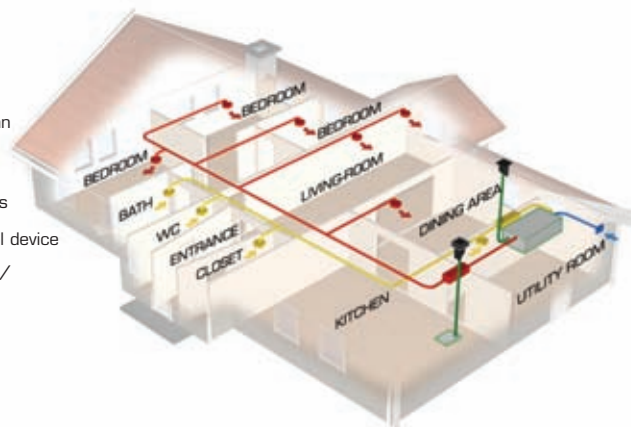

General

The purpose of ventilation is to provide us with healthy fresh air indoors. It removes old, stale air and takes in clean, fresh air. Of course its main task is to ensure that the air indoors is healthy to breathe. Nowadays ventilation is also focused on energy, on saving energy costs by using ventilation with heat recovery.

Ventilation in homes – technical solutions

There are three key types of technical solution for ventilation. Naturally there are variations within these but the three main types are:

- Natural ventilation systems
- Mechanical exhaust air systems
- Balanced ventilation systems containing supply air and exhaust air fans. These are also called mechanical supply and exhaust air systems.

Today the last two systems are almost always combined with some form of heat recovery.

Apart from natural ventilation, good control systems are needed for all ventilation systems.

NATURAL VENTILATION

The principles of natural ventilation are simple. Warm air in the house rises and leaves through air ducts creating a partial vacuum in the building. This partial vacuum sucks in new air from outside through gaps in the structure of the house. The greater the temperature difference between outdoor and indoor air, the greater the air volume replaced.

However, natural ventilation, even when it is working well, has some unwelcome effects. Airflows great enough to provide healthy air indoors waste energy as heated air escapes literally straight up the chimney. Remedying this by reducing the air flow has a negative effect on the indoor environment making the air stale. Another problem with natural ventilation is that it cannot be controlled, it remains “as it is”. The air is also not cleaned, one cannot install a filter in all the gaps.

MECHANICAL EXHAUST AIR SYSTEMS

Mechanical exhaust air ventilation is just that. Air is sucked out of the home using fans. Air is sucked out of the kitchen, toilets, bathrooms and utility rooms and replaced in the same way as for houses with natural ventilation, through outdoor air terminal devices, airing panels and leaks in the building.

However, one common difference is that air is generally taken in through vents or airing panels, not through gaps under doors or other leaks. It is important not to remove air from bedrooms and reception rooms as the air would then be

flowing in the wrong direction. This would result in cooking smells and humidity spreading throughout the home.

Mechanical exhaust air ventilation is popular because it is cheap and easy to install. However, in the past mechanical exhaust air systems have often had the same disadvantages as natural ventilation with outdoor air, it is not cleaned sufficiently and is cold in winter. Nowadays supply air terminal devices in outer walls can be fitted with filters that remove the worst of the contamination. Careful design and positioning of these devices can counteract draughts.

BALANCED VENTILATION SYSTEMS (FT/FTX SYSTEMS)

The most complete form of ventilation system is the balanced ventilation system. Fans control both the supply and exhaust air, this achieves full control of the volume of fresh air, which does not occur in the other two systems. In fairly well sealed houses this means that almost all supply air comes through supply air terminal devices as the system is not based on a partial vacuum. This also means that it is easy to clean the air, filters are installed on the air intakes.

These systems are normally more expensive to buy but do allow lower energy consumption and better comfort. Today these systems are both effective and quiet and there is plenty of research showing that if one wants an installation with low energy consumption and good indoor climate one needs a balanced ventilation system. Low energy consumption requires heat recovery and energy-efficient products such as fans, filters and heat exchangers.

A good balanced ventilation system is both stable and flexible. Stability means that the system must work as intended, almost irrespective of what happens in the house. Flexibility means that the ventilation can be controlled to meet requirements. If there are more people in the house more ventilation is needed than if the house is empty. Such on-demand control of ventilation is becoming more and more common. This, and heat recovery, reduce the energy requirement and so lower the operating costs of the house.

A balanced ventilation system with heat recovery has a heat exchanger. Instead of releasing the used, warm air straight into the atmosphere, it passes a heat recovery unit in which the exhaust air heats the cold outdoor air as it comes in. In new installations, heat recovery is often a matter of course.

CONTROL SYSTEMS

Control systems have a crucial effect on the function of the installation and the air quality in the house. A good control system will maintain set functional requirements for a long time with a minimum of energy use. Fläkt Woods has control systems for the various systems.

Source: Indoor Air — The Silent Killer

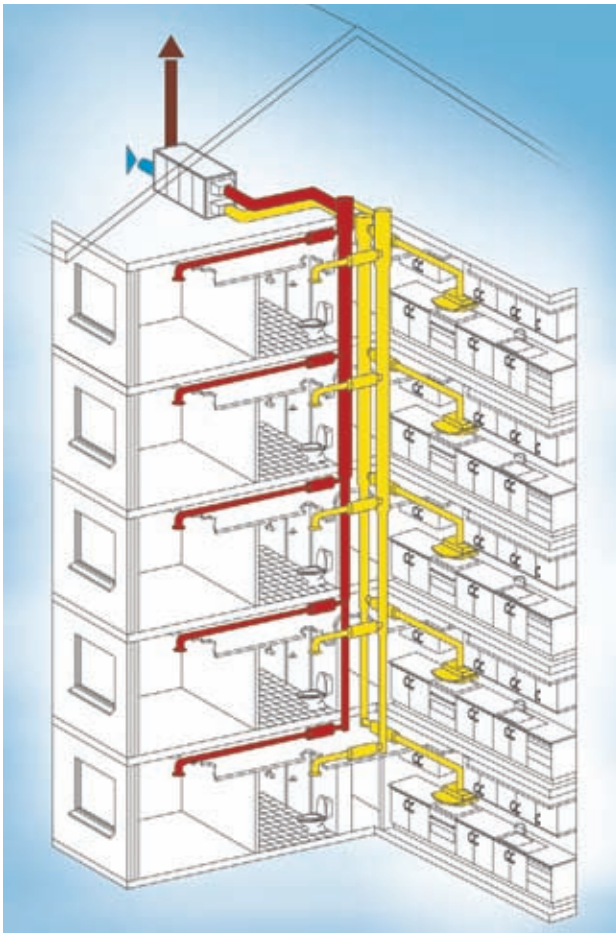

With heat recovery

BALANCED VENTILATION WITH HEAT RECOVERY

The most complete form of ventilation system is the balanced ventilation system with heat recovery. In a supply and exhaust air system with heat recovery the outdoor air vents are positioned in living rooms and bedrooms and the exhaust air vents in the bathroom, toilet and utility room. This system makes use of the heat in the used ventilation air, air that would otherwise be released straight out into the cold.

The heated indoor air passes through a heat recovery unit before being expelled and is used to heat the incoming outdoor air. This saves energy while providing a better climate indoors. So it is possible to control the air quality and the air volume coming into the home.

Balanced ventilation systems also have effective filters which filter out dust and pollen from the outdoor air.

Without heat recovery

Mechanical exhaust air ventilation is just that. Air is sucked out of the home using fans.

Outdoor air is often taken in through slot ventilators in the window frames. The warm used air is sucked out through exhaust air vents in wet rooms and through the kitchen extractor. These exhaust air vents are connected by a ducting system from which the air is expelled using an exhaust air fan.

The disadvantage is that outdoor air is untreated when it is taken in, this causes cold draughts when it is cold outside. This leads to the outdoor air vents being closed and never reopened which results in the ventilation system ceasing to work. Also the outdoor air is not filtered when it comes into the home.

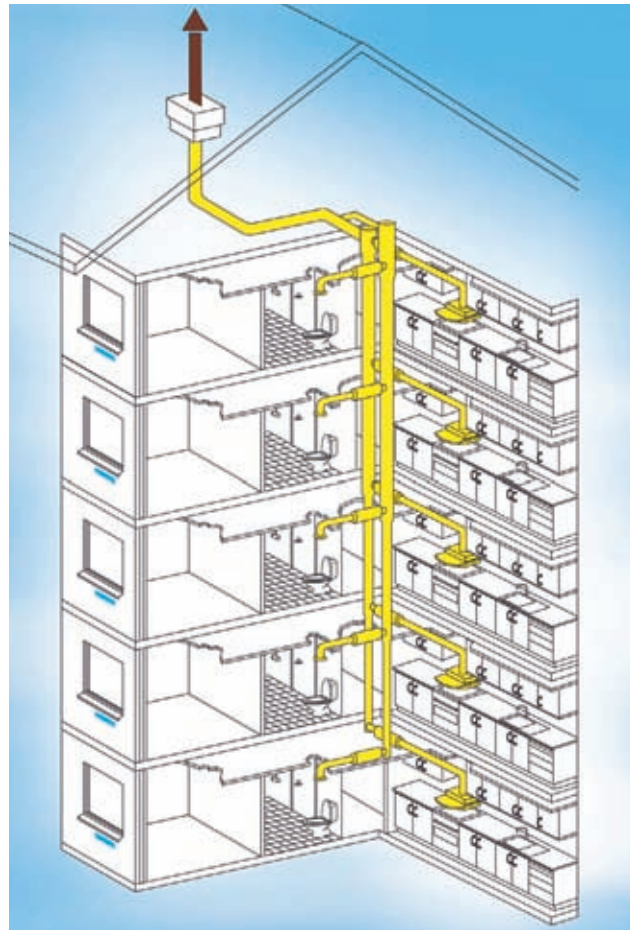



Reference section



The right room temperature

What is the right temperature?

The recommendations available for the temperature are based on research into efficiency and feelings of comfort.

Temperature and comfort

The ISO standard in the indoor climate field (SS-EN ISO 7730) specifies the guideline values below for what is to be regarded as a pleasant, comfortable indoor climate. For more information on indoor climate: see *References* on page 123.

Comfort requirements under *winter conditions* and light, mainly sedentary activity. In accordance with international standard SS-EN ISO 7730.

- The operating temperature must be between 20°C and 24°C.
- The vertical difference in air temperature between 1.1 m and 0.1 m above floor level (head and ankle height) must be less than 3°C.
- The surface temperature of the floor should normally be between 19°C and 26°C, but systems with floor heating may be permitted a floor temperature of 29°C.
- The average speed of the air must be less than 0.15 m/s.
- The radiation temperature symmetry due to windows or other cold vertical surfaces must be less than 10°C (in relation to a small vertical plane 0.6 m above floor level).
- The radiation temperature symmetry due to a warm (heated) roof must be less than 5°C (in relation to a small horizontal plane 0.6 m above floor level).

Comfort requirements under *summer conditions* and light, mainly sedentary activity. In accordance with the standard SS-EN ISO 7730.

- The operating temperature must be between 23°C and 26°C.
- The vertical difference in air temperature between 1.1 m and 0.1 m above floor level (head and ankle height) must be less than 3°C.
- The average speed of the air must be less than 0.25 m/s.

SS-EN ISO 7730 corresponds to class TQ2 in the R1.

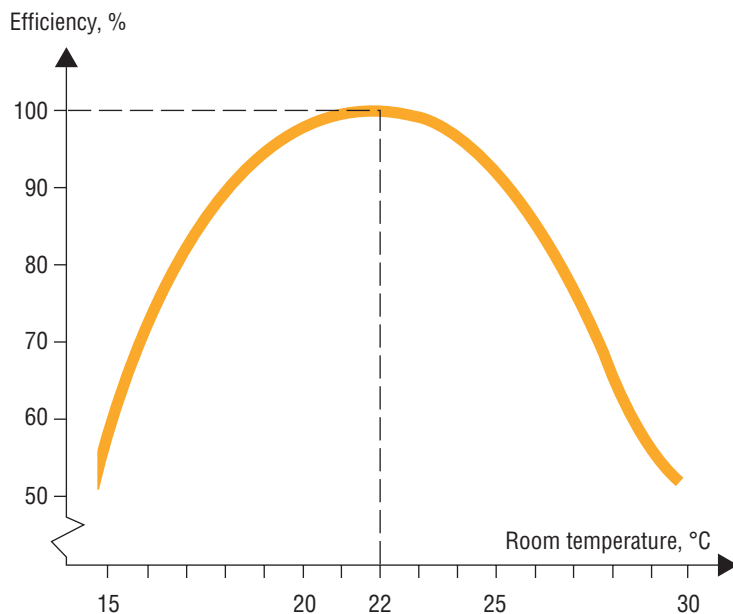

Temperature and performance

Everyone knows that performance suffers when the surroundings are too hot (or too cold). But by how much? And how can we measure this change?

David Wyon, formerly of Statens Institut för Byggnadsforskning, has studied these questions in depth. He has come up with the notion that the ideal temperature for maximum performance varies slightly from person to person. But even at a deviation of one or a couple of degrees from the ideal temperature, impaired efficiency can be measured. The above diagram shows the average of a large number of measurements of efficiency. For other types of business, the type of clothing and physical activity have to be taken into account in order to achieve an optimum indoor climate.

□ FLÄKT WOODS RECOMMENDS:

A climate system should not just be dimensioned so that the climate is perceived as somewhat pleasant (level B, page 17); but it should be dimensioned so that maximum performance is achieved (level C, page 17). Efficiency and concentration levels are impaired at just a couple of degrees' deviation from the best indoor temperature.

Temperature and economy

An example

The following example based on cost levels for 2007 indicate how much money can be earned thanks to greater efficiency if you invest in a modern climate system instead of a simple ventilation system. The calculations are based on David Wyon's research results. It may be stated that the increase in costs which a good climate system involves is absorbed during the first year because productivity may increase by up to 20%.

Criteria

The example refers to a person carrying out typical indoor work in an office. We assume that he is 100% efficient as long as the temperature is below 24°C. In the example, we compare the efficiency in two different climate cases: if the room has a Level A system (no temperature requirements), and if it has a Level C system (individual climate, max. 24°C).

WAGE COSTS AND WORKING HOURS

We assume that the calculated annual wage cost (inc. payroll overhead costs) is € 55 400. The work is carried out over 200 working days. At full efficiency, therefore, the person does work worth € 277 every day.

TEMPERATURE RANGES

We calculate the efficiency change within three temperature ranges. The data for the calculation can be found in the diagrams. The diagram on the previous page shows the efficiency in the various temperature ranges. The diagram below shows the number of working days over the year within the various temperature ranges. See the following table.

Temperature range	Efficiency	Level A	Level C
Over 27°C	75%	15 days	0 days
26°C–27°C	80%	20 days	0 days
24°C–26°C	95%	50 days	0 days
Below 24°C	100%	115 days	200 days

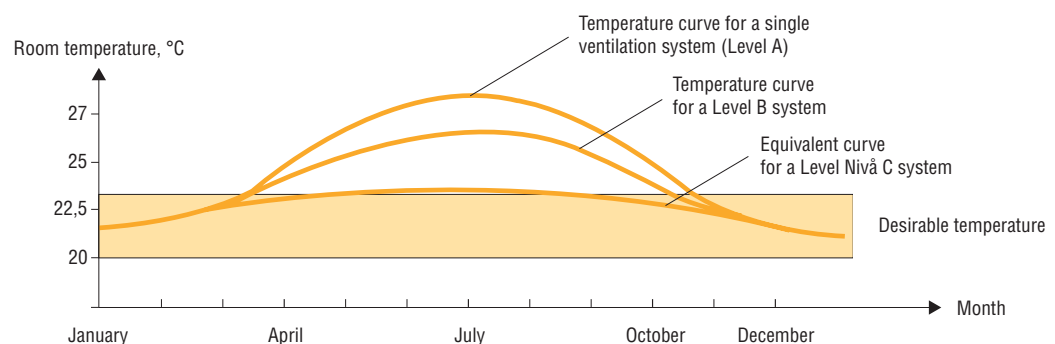

Count as follows

For a Level A system, losses in efficiency during hot days are calculated in accordance with the following list. The loss is specified in relation to a Level C system, which gives 100% efficiency all year round.

1. RANGE OVER 27°C — 15 days, 75% efficiency

Wage costs	€ 4 158
Performance.....	€ 3 148
Loss compared with Level C.....	€ 1 039

2. RANGE 26°C — 27°C — 20 days, 80% efficiency

Wage costs	€ 5 543
Performance.....	€ 4 435
Loss compared with Level C.....	€ 1 109

3. RANGE 24°C — 26°C — 50 days, 95% efficiency

Wage costs	€ 13 859
Performance.....	€ 13 166
Loss compared with Level C.....	€ 674

4. RANGE BELOW 24°C — Full efficiency.

No loss compared with Level C.	
Total saving:	€ 2 822 a year!

Over a total of 85 of the 200 working days in the year, people's efficiency will therefore be impaired if they work on premises with a Level A climate. Compared with a Level C climate (full efficiency over all 200 days), this is equivalent to a wage cost of € 2 822 for which there is no corresponding performance.

Ventilation or climate system

According to the example above, you would save € 2 822 per person a year in increased efficiency if you invest in a climate system instead of a ventilation system. There is reason to carry out another cost comparison which also includes investment costs. We usually apply the following investment costs:

Ventilation system (Level A, per m ²)	€ 92
Climate system (Level C, per m ²)	€ 141
Difference (per m ²)	€ 49

A normal office is usually equivalent to approx. 18 m². Additional investment to ensure a good climate for this office all year round then totals:

$$18 \text{ m}^2 \times € 49 \dots\dots\dots = € 882$$

The annual additional capital cost per employee is then € 77, if you assume 20 years' depreciation and 6% actual interest (annuity factor 0.08718). $0.08718 \times € 882 = € 77$. The operating code for a level C system does not necessarily need to be higher — in some instances, it may be lower! The annual income in the difference between the efficiency increase of € 2 822 and the additional capital cost of € 77.

$$€ 2 822 - € 77 \dots\dots\dots = € 2 745$$

FLÄKT WOODS SUMMARISES

□ The climate system will pay for itself in less than a year. What other investments in a workplace would do that? Even if the additional investment in the system were twice as great, or if the simpler system were completely free, this is still a good investment!

Heating and cooling

Remove heat

The most important parameter when choosing a system solution for premises is generally the need to remove (cool the air) on the premises in question. If the cooling output requirement is low, the need to be able to vary the capacity is also low. If the cooling output requirement is enormous, you will be unable to perform this task using just air-based systems; you will have to supplement these with water-based systems. The cooling output requirement is influenced by the following factors:

- Outdoor climate (geographical location)
- Window size and sun screens
- Heat sources
- The requirements of the company
- Room placement (direction, inner rooms or perimeter rooms)

Supply heat

Heat may need to be supplied for a number of different reasons:

- 1** The room has windows which give rise to radiation losses and draughts.
This type of heat requirement is normally met by means of a panel radiator beneath the window. The radiator is controlled by an outdoor temperature sensor in such a manner as to compensate for the effect of the outdoor temperature.
- 2** The outdoor air is so cold that it needs to be heated.
This type of heat requirement is best met by means of recovery of the thermal energy in the exhaust air. Rotary heat exchangers in the principal unit can recover up to 85 % of the thermal content of the exhaust air.
- 3** The ventilation requirement is so great that the supply air provides too much cooling. This type of heat requirement is best met by afterheating the supply air to the room.

Calculate the cooling effect correctly

Cooling is generally required

A normal room is constantly subject to varying thermal loads, leading to an effect on the temperature of the air in the room. The consequence of this is that if so required, heat has to be removed or supplied. Normally excess heat is generated which has to be removed. It is important to calculate thermal loads accurately. The greatest demand for correct calculation must be made if you want to design a system without a cooling machine.

Manual calculation

As most of a room's inner and outer thermal loads vary over the day and according to season, the amount of heat that needs to be supplied or removed also varies. The simplest way of statically calculating the requirement for cooling effect is to add the total of positive and negative thermal loads. This greatly simplified method of calculation will, however, lead to a system which is overdimensioned and so unnecessarily expensive.

A more accurate manual calculation is very complicated and extensive, and impossible to carry out in practice. Factors to be taken into account include — for example — permitted change in room temperature, radiation exchange between room areas, heat storage in buildings and the effect of heat given off by electrical equipment.

Simplified methods

There are a number of simplified manual computerised calculation methods on the market. The accuracy is not sufficient among these either, which results in the fact that systems tend to be overdimensioned. With this type of simplified program, it is not possible to link the results to an anticipated room temperature process.

Accurate computer calculation

Accurate computer calculation is the best way for a planner to locate secure data for his dimensioning. The advanced calculation programs on the market provide every opportunity for you to take into account all parameters which affect the capacity requirement. These programs generally give the user to opportunity to choose himself the detail in which he wants to execute the calculations, depending on the current phase of planning. With an advanced calculation program, you can also calculate a room temperature process to really assure yourself of the quality of the system. The Fläkt Woods system selection program collects together all these functions in a single application for calculating the cooling and heating effect for various rooms.

INFORMATION REQUIRED

The following details are required to be able to execute a detailed cooling effect calculation:

- 1 Location and orientation of the building.
- 2 Objects which overshadow the perimeter walls of the building
- 3 Wall, floor, inner ceiling and outer roof structure
- 4 Room layout and room sizes
- 5 Sun protection¹⁾
- 6 Operating hours and operations
- 7 Proposed schedule for lighting, operations and internal equipment and processes that give off heat
- 8 Required temperature and relative humidity, together with permitted temperature slides and functional limits for projected system control
- 9 Ventilation requirement

¹⁾ When using certain types of external sun protection, more cooling effect may be required over a spring day than over a summer day, due to the fact that the sun shines from lower angles in spring than is the case in summer.

□ FLÄKT WOODS RECOMMENDS:

Fläkt Woods recommends that you use an advanced calculation program. Only then can you predict and show the customer what indoor climate they will be getting. For a serious client, this is an obvious requirement.

System selection matrix and air transfer

Type of building	System solution	Air transfer											
		Mixed					Displaced						
		Cooling requirement (W/m ² floor area)											
		0	20	40	60	80	100	0	20	40	60	80	100
Offices	CAV		0-30						0-35				
	VAV		20-60						20-40				
	Fan coil			40-70									
	Chilled beam			40-90								60-90 (1)	
Hotels	CAV		0-20						10-25				
	VAV			20-50					20-45				
	Fan coil			20-45									
Hospitals	CAV		0-20						10-25				
	VAV			20-50					20-55				
	Chilled beam				50-90							60-90 (1)	
Public premises	CAV		0-20						10-30				
	VAV			20-50					20-40				
Department store	CAV		0-40						10-40				
	VAV			20-70					20-50				
	Fan coil			40-90									
	Chilled beam				40-90							60-90 (1)	

= Best choice

= Acceptable choice

1) = In the case of large air flows, air can be supplied using a low impulse device. The air transfer in the room is mixed due to the dominant effect of the chilled beams.

Typical rooms and effect areas	W/m ² floor area
Cubicle system with collective regulation	0-30
with individual regulation	30-50
Conference room	20-80
Guest rooms normal standard	0-25
high standard	25-50
Care room	0-30
Examination and treatment rooms	20-60
Intensive care	> 50
Conference room	20-80
Theatres and cinemas	40-60
Restaurants	30-70
Training premises	20-50
Food halls	20-40
General departments	30-60
Home electronics departments	40-80
Lighting departments	50-100

Quick choice matrix — selecting the right room system

The matrix on the left provides a summary of how to select systems and air transfer. Systems are selected by room. As a basis for the choice of system, the cooling output requirement is selected in the first instance. The best choice of system and air transfer technique is shown in blue. Yellow indicates an acceptable choice.

Heat recovery

Recovery units in the air conditioning system

Recovery of energy from exhaust air generally provides the financial criteria to allow you to create a good indoor climate. Significant energy savings can be made by means of heat recovery from exhaust air (ventilation or process air). A saving which normally results in the investment made paying for itself within a very short time, while at the same time the air conditioning installation's environmental impact (need for primary energy production) is reduced to a crucial extent. Heat recovery must be controllable, otherwise the energy savings are limited.

WHY NOT RETURN AIR?

Return air mixture impairs the quality of the room air as many contaminants cannot be filtered out. In modern comfort systems, nor is there any reason to use return air as the air flow in every room or zone is equal to the ventilation requirement as there are no cooling requirements. To prevent exhaust air from leaking across to the supply air, the fans must be positioned such that inappropriate pressure differences do not occur.



Regoterm®,
rotary heat
exchanger

The unit range from Fläkt Woods uses four different types of recovery unit.

- Rotary heat exchanger — REGOTERM®
- Plate heat exchangers — RECUTERM®
- Liquid connected heat exchangers — ECONET® or ECOTERM®

Which recovery unit should you choose? None of these is best for everything, and from all standpoints. It is often the case that several types are possible in each individual installation.

TECHNICAL FACTORS

A number of technical factors have to be taken into account when selecting recovery units in the system. It is important to ensure that efficiencies, pressure drops and environmental durability correspond to the set requirements for profitability, but other factors may also be crucial to the choice. If, for example, there are substances in the exhaust air which are hazardous to health, such as solvents, or if there is a risk of the transfer of smells, the requirement for the leakage factor is crucial. Factors influencing the choice of recovery unit:

- Efficiency
- Environmental durability
- Reliability
- Available space
- Freezing
- Cooling recovery
- Pressure drop
- Leakage
- Duct connection
- Regulation
- Transfer of moisture
- Transfer of smells

Profitability

Profitability in the event of installation of recovery units is determined by requisite investment, power/energy saving, power/energy cost and maintenance cost. The saving made is largely dependent on efficiency and the overall operating time

of the recovery unit over the year. It should be noted that the operating time of the recovery unit is largely influenced by the temperature difference between exhaust–supply air — a large difference results in a shorter operating time.

The power/energy cost is largely dependent on the recovery unit’s pressure drop and the consequently increased cost of electricity for the fans (two units). Thus you must always take into account both the efficiency and the pressure drop in your assessment of profitability. Below, the temperature efficiency and pressure drop have been compared in a drop equivalent to 1.0 m³/s per filter module (approx. 2.8 m/s). At this flow, the energy consumption per 100 Pa of pressure drop increases by 800–1000 kWh/year.



Econet unit

	Temperature efficiency (%)	Pressure drop (Pa)
Rotary heat exchanger	75–85	150
Plate heat exchanger	55–65	150
Ecoterm	50–60 ¹⁾	270
Econet	60–75 ¹⁾	320

¹⁾ 30 % ethylene glycol

□ TO SUMMARISE

Rotary heat exchangers are normally the first choice due to their superior energy saving in combination with a low pressure drop. If for any reason the rotary heat exchanger is not acceptable due to a duct connection or risk of transfer of smells, one of the other three recovery units is selected instead.

Econet is a system which utilises waste heat and cooling efficiently so that the total energy cost is lower despite a higher pressure drop. However, this has to be calculated on the basis of the relevant criteria available.

The ranking list below may serve as a general guide when choosing recovery units.

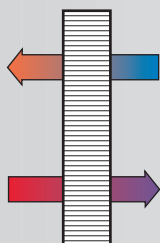

ROTARY HEAT EXCHANGERS, REGOTERM®

Rotary heat exchangers are used for the recovery and transfer of heat (and cooling in some cases in summer), and any moisture from exhaust air to supply air. Rotary heat exchangers are particularly advantageous for systems in which high temperature and moisture efficiency are desirable. Common applications: offices, hotels, schools, hospitals, public premises and industrial premises. As there is a risk of transfer of smells, this heat exchanger is not used for homes, operating theatres and suchlike. Typical temperature efficiency: 75–85%

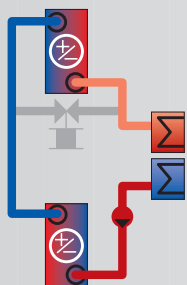

LIQUID CONNECTED HEAT EXCHANGERS, ECONET

Econet is a development of Ecoterm, with greater efficiency and a number of additional functions. In the Econet concept, all energy functions are gathered together in a collective circuit for heat/cooling recovery, heat and cooling. The coils are extremely efficient, and the temperature difference between the liquid and the air is small. It is possible to utilise low tempered energy sources or to use large temperature differences for the heating or cooling water. The system optimises the liquid flow in the coils to produce the best possible heat recovery. Typical temperature efficiency: 60–75%

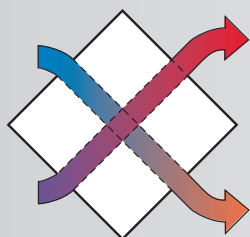
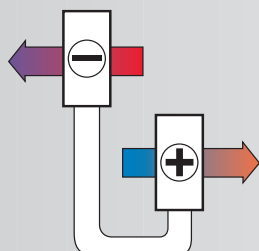

PLATE HEAT EXCHANGERS, RECUTERM®

Plate heat exchangers are used in normal comfort systems and in systems where a small amount of leakage (a few %) can be accepted. The transfer of smells is eliminated by arranging the pressure conditions so that any leakage takes place from supply air to exhaust air. Application applications for heat recovery with plate heat exchangers are: catering, the pharmaceutical industry, bathing facilities, homes and nurseries. Typical temperature efficiency: 55–65%



LIQUID CONNECTED HEAT EXCHANGERS, ECOTERM®

Liquid connected heat exchangers are used in systems where no leakage and no transfer of smells are allowed to occur. Liquid connected heat exchangers are also used in locations where plate heat exchangers will not fit. Another common installation is at points where supply air and exhaust air units are separated. Typical temperature efficiency: 50–60%

	Efficiency	Capacity reduction	Pressure drop	Leakage	Space	Duct connection	Adjustment	Freezing	Moisture efficiency	Transfer of smells	Corrosion resistance	Cooling recovery	Reliability
	Very advantageous	Very advantageous	Very advantageous		Very advantageous	Very advantageous	Very advantageous	Very advantageous	Very advantageous		Advantageous	Very advantageous	
	Advantageous	Advantageous		Very advantageous	Very advantageous	Very advantageous	Very advantageous	Advantageous		Very advantageous	Very advantageous	Advantageous	
	Advantageous	Advantageous	Advantageous	Advantageous		Advantageous	Advantageous	Advantageous		Advantageous	Advantageous	Advantageous	Advantageous
		Advantageous		Very advantageous	Advantageous	Very advantageous	Advantageous	Advantageous		Very advantageous	Very advantageous	Advantageous	

Very dark blue = very advantageous

Light blue = advantageous

Econet heat recovery



In the Econet concept, all energy functions are gathered together in a collective circuit for heat/cooling recovery, heat and cooling. This requires fewer components in the form of heating/cooling coils, pumps, vents, pipes, insulation, etc. This results in a shorter, more compact unit.

These coils are extremely effective, and the temperature difference between the liquid and the air is small. This permits either low temperature energy sources or large temperature differences to be used for the heating or cooling water. Heat recovery is also improved with the aid of Econet, with 10–20% compared with traditional coil recovery units.

The Econet systems are supplied together with the EU module unit. The system is selected from the unit selection programme and consists of two or three heat exchangers, i.e. one or two coils in the supply air unit and one in the exhaust air unit. The consignment also includes a pump unit, consisting of a pump unit and a control function for energy recovery optimisation. All the necessary sensors in the pump unit and software and project-based parameters in the frequency inverter and control cabinet are installed at the factory. The pipes in the pump unit are insulated, and the pump unit is located on a separate stand. Econet can be supplemented with efficiency measurement and provided with two pumps.

SYSTEM FUNCTION

Heat recovery: The system optimises the liquid flow in the coils so as to ensure the best possible heat recovery. The liquid flow is regulated by the frequency controlled pump.

Heat recovery + additional heat The system optimises the liquid flow in the coils so as to achieve the best possible heat recovery. Additional heat may be supplied to the circuit, either directly or via a heat exchanger.

Cooling: The exhaust air coil is disconnected, and additional cooling is supplied to the circuit so that the cooling liquid circulates only via the supply air coil. Additional cooling is supplied to the circuit directly or via a cool exchanger.

Cooling recovery (e.g. IEC): The exhaust air is cooled by means of humidification with indirect evaporative cooling (Coolmaster). The cooling effect is transferred via the recovery system to the supply air. The liquid flow is optimised, and additional cooling can be supplied if so required.

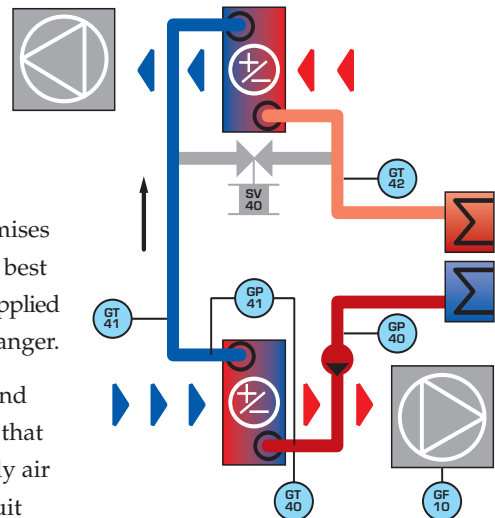



Airborne cooling

Coolmaster

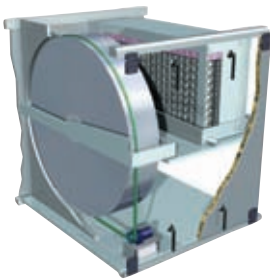

Coolmaster

Indirect Evaporative Cooling (IEC) involves cooling of the exhaust air or outdoor air via an evaporative humidifier, and then the cooled exhaust air undergoes heat exchange with the supply air via a heat exchanger. See Figure 1. In many cases, you can create a good indoor temperature at a very low cost. It is possible to reduce the supply air temperature by 5–6°C. The Coolmaster works best in combination with:

- small internal loads
- displaced air transfer and tall ceilings inside the premises
- in locations with a relatively dry climate

In the case of large internal loads, the exhaust air is hotter than the outdoor air.

You can then cool to a lower temperature by humidifying the outdoor air instead of the exhaust air.

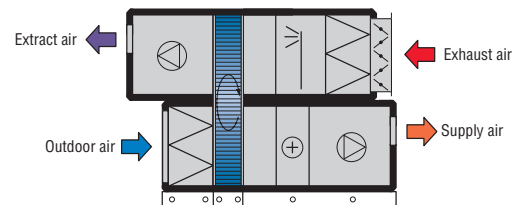

Cooling machines

Compact cooling units for cooling and heat pump operation are complete units.

This unit is available with both water and air-cooled evaporators. Air-cooled cooling machines often have a principal condenser unit and one or more evaporator coils mounted directly in the air conditioning unit.

Cooling machines for ventilation systems often run at a partial load which is less than 60% of their maximum capacity. This places great demands on high energy efficiency at both partial load and maximum load.



Cooler

The cooling unit is a complete cooling device, complete with all components (including controls and regulation). This is supplied filled from the factory, having undergone test operation first. The cooling unit requires a 0–10 V control signal and a power feed. This can be interlocked over the exhaust air fan or over a sensor. Alarms may be issued in the form of a buzzer — see “Electrical data” in the product catalogue.

The cooling principle is direct expansion with three-stage capacity regulation. The condenser is located in the exhaust air and the cooling coil is located in the supply air. Controls and regulators, as well as all components which you normally need to access during servicing, are located in a service section. This service section may be opened during operation to check performance. The compressors are located in the exhaust air.

When choosing a cooling unit, you work on the basis of the unit size and then select an effect variant which is equivalent to the cooling requirement. An outdoor placement and water-cooled condenser are available as accessories. A water-cooled condenser is used when you do not have enough exhaust air to remove the condenser heat, or if you want to preheat the hot tapwater. The Cooler cooling unit must be used when you want to implement:

- A tested, trialled and inexpensive cooling system.
- Simple, fast and safe planning and installation.
- A high cooling factor.



Fan coils

Fan convectors (Fan coils) – Room systems using liquid as a cooling bearer

Systems with fan convectors are appropriate for use when there is a great need to remove heat, combined with stringent demands for individual regulation. Fan convectors also react quickly to changes in load (cooling or heat requirement). Common applications are hotel rooms, hospital wards and classrooms.

In this type of system, the ventilation system and cooling system are separate from one another, which means that smaller ventilation duct dimensions are required than in a VAV system.

FUNCTION

The working principle for a fan convector is that the air circulates over the cooling /heating coil in the fan convector with the aid of the built-in fan. The quantity of air and supplied heat or cooling is controlled via a room thermostat and regulation of the fan speed so that the room temperature set is maintained.

We differentiate between what are known as dry cooling and wet cooling. Dry cooling means that the cold water temperature to the cooling coil does not fall below the dewpoint of the air, which is appropriate for Nordic conditions. Wet cooling means that the temperature of cold water supplied to the coil falls below the dewpoint of the air, so in the case of wet cooling a container must be provided for collecting condensation.

When dimensioning fan convectors, it is important to bear in mind the risk of high noise levels and draughts.

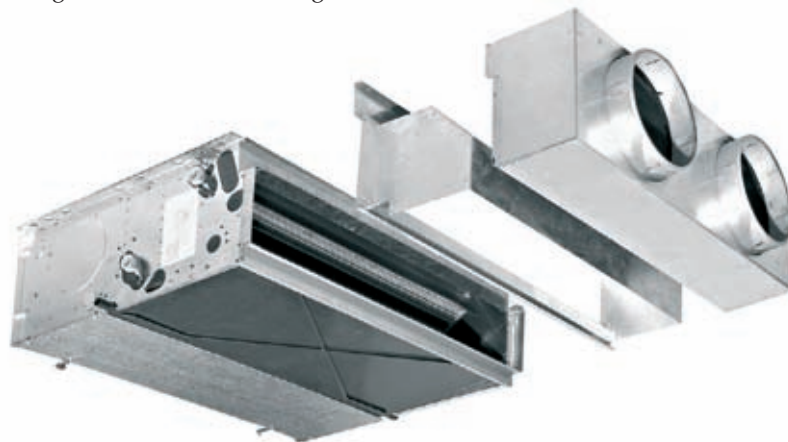

VAV

VAV — Variable flow system with air as a cooling carrier

In a VAV system, the ventilation flow is adapted according to the needs of the room. When the indoor temperature begins to rise, the ventilation flow increases, as does the cooling effect. When the indoor temperature falls — i.e. there is a reduced load — the ventilation flow is also reduced, resulting in greater energy efficiency and good operating economy.

VAV systems are used in applications with major variations in load and/or where demands are made for individual regulation of the indoor climate.

We differentiate between pressure-dependent and pressure-independent systems, the latter being preferable as it involves smaller duct dimension and simpler planning and adjustment. A pressure-independent system requires an air flow regulator which measures the air flow in the flow variator.

The main component is the flow variator, this is what uses a signal from the room's temperature regulator to regulate the air flow so that the set indoor temperature is maintained regardless of load. The flow variator has a set min. air flow which is determined by the air flow required to achieve good air quality and a max. air flow determined by the room's calculated cooling output requirement. If there are any pressure changes in the duct system, the air flow regulator compensates for these so as to maintain the requisite air flow.



Chilled beams

Systems with chilled beams are appropriate for use where there are major cooling requirements and/or when individual regulation of the temperature is demanded. At normal room heights in offices, for example, the max. cooling effect is 80–90 W/m² of floor area. This limit is set to the max. permitted rate in the occupation zone. This is why rooms with higher ceilings permit the option of supplying a greater cooling effect. As with all cooling requirement calculation, you have to take into account the dynamics and accumulation ability of the building. Straight “up and down” totting up of the “gross effects” gives a cooling requirement which may be some 50% too high.

The supply air flow is responsible for the air quality in the room and also provides basic cooling. The maximum recommended low temperature of the supply air is 10°C. In some cases, the supply air temperature may be subject to weather compensation; i.e. be increased by a few degrees when the outdoor temperature falls. The chilled beam covers the rest of the cooling requirement. The water flow varies depending on demand with the aid of a room sensor. In comparison with a system where cooling is taken all the way to the rooms with air, a chilled beam system reduces the need for space for air conditioning units and ducts.



FUNCTION OF THE CHILLED BEAM

In systems with chilled beams, the air is cooled by means of cold water, and the supply airflow rate is dimensioned in a way that fulfils the requirements of good air quality.

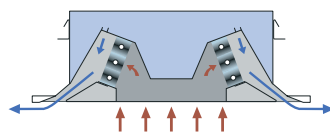

Supply air beams (also known as active beams) work by induction. The incoming supply air drags room air with it, which is sucked through the coil for the beam. The total flow, which is the sum of the supply air flow and the circulation air flow, emerges through the outlet gap in the coil. The circulating room air flow is 3–4 times as great as the supply air flow.

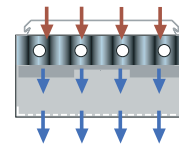

Passive beams work with a reverse flue effect, which means that the cooler air inside the beam has a higher density than the ambient air. This density difference, combined with the height of the beam, forces the circulating room air through the beam's coil. Fläkt Woods offers a complete range of climatebeams to suit most requirements, and we have placed great emphasis on the function for providing the best comfort in the room.

1. SUPPLY AIR BEAMS

Supply air beams, with their long slot air diffusers, provide an opportunity for the maximum supplied cooling effect without the speed in the occupation zone becoming troublesome. This is because the supply air from the beam is mixed very well with room air as the contact surface with the ambient air is extremely large. In the maximum case, the air flowing out covers a large part of the ceiling area. One-way beams are placed at walls, while two-way beams are placed inside the room.

2. CONVERSION OF THE FLOW PATTERN IN THE ROOM

Fläkt Woods IQ beams have separately adjustable hole lengths on both sides. This means that the left/right air flows can be set to any proportions. When a beam is placed close to a wall, for example, a 30% flow can be selected towards the wall, and 70% in the other direction. When a system is converted, partition walls are often moved, and it is possible with the adjustable hole lengths to easily redistribute the air flow from each beam so as to prevent problems with draughts. Another IQ beam function is FPC, which allows the air to be angled in different directions. Together, these two functions provide major flexibility during installation.

3. PASSIVE BEAMS

Passive beams provide a mainly downward-facing air flow in the room. In a low room, therefore, it is not appropriate — with no further consideration — to place the beam above a workstation where someone sits to work, as this will cause draughts. The air is supplied using separate supply air devices in rooms with passive beams. Both mixed and displaced devices ensure good comfort in the room in combination with passive beams. With displaced air transfer, the temperature difference between the floor and the ceiling will be reduced, but the displaced function will be maintained. In rooms without false ceilings, it is important to ensure that the air flow from mixed supply air devices does not disrupt the inflow of air to the beam, which would reduce the cooling effect of the beam.

4. MULTIFUNCTIONAL CHILLED BEAM

In some locations, a beam is required which includes functions which are otherwise installed separately in the room. This phenomenon is known as multifunctional chilled beam. The Fläkt Woods IQID chilled beam is a multifunctional chilled beam which — fully featured — may include the following functions:

- Supply air
 - Increased air flow
 - Cooling and heat
 - Comfort controls
 - Control and regulation equipment
 - Lighting
 - FPC (Flow Pattern Control)
 - Prepared for sprinklers
- (Adjustable hole length for the supply air)

PLATE-TYPE COOLER

Available in two lengths, 600 and 1200 mm, to fit standard false ceilings. IQCA has CSC (Coanda Safety Control), which ensures adhesion of the air jet to the false ceiling.

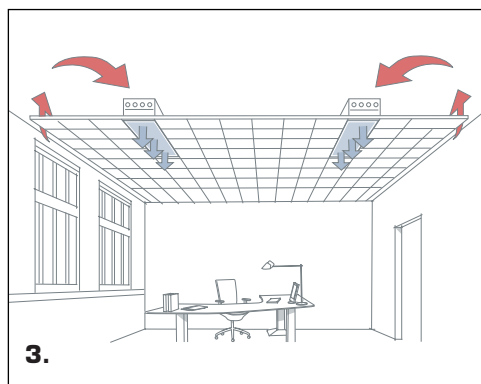
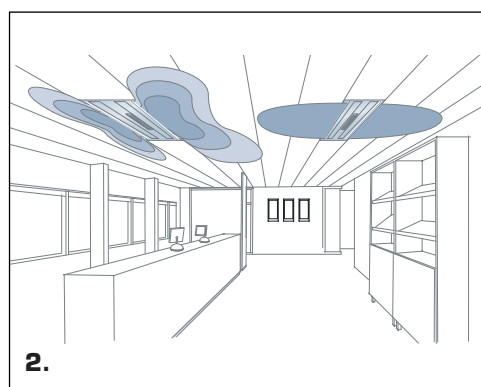
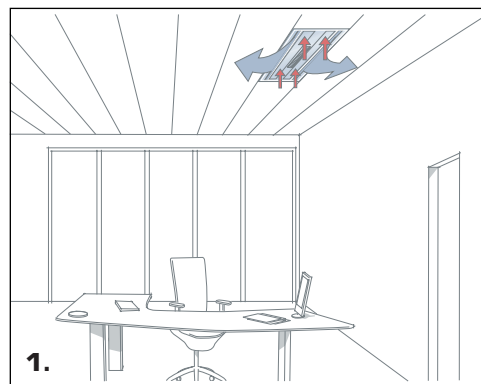

Perimeter wall unit

Perimeter unit— room system using liquid as a cooling bearer

The working principle for a perimeter wall unit is the same as for chilled beams, i.e. it uses the driving force of the supply air, which creates an air flow through the coil by means of induction which results in heated or cooled air being blown out of the unit.

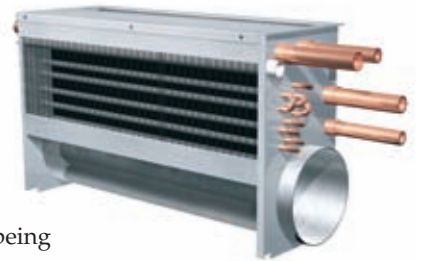

Perimeter wall units are installed along the perimeter walls of the building beneath site-built window benches and may be connected in series. Perimeter wall units are suitable for offices, schools, banks and hotels, and can be used when constructing new buildings and renovating old ones.

The room regulator controls the heating and cooling vents via a setting device in order to maintain a set temperature.

The total cooling effect in a perimeter wall unit is determined by the sum of the cooling effects of the supply air and the coil.

It is generally the cooling output requirement of the room which controls the dimensioning of perimeter wall units; the heat capacity which follows on from the selected size is often sufficient to meet any heat requirements.

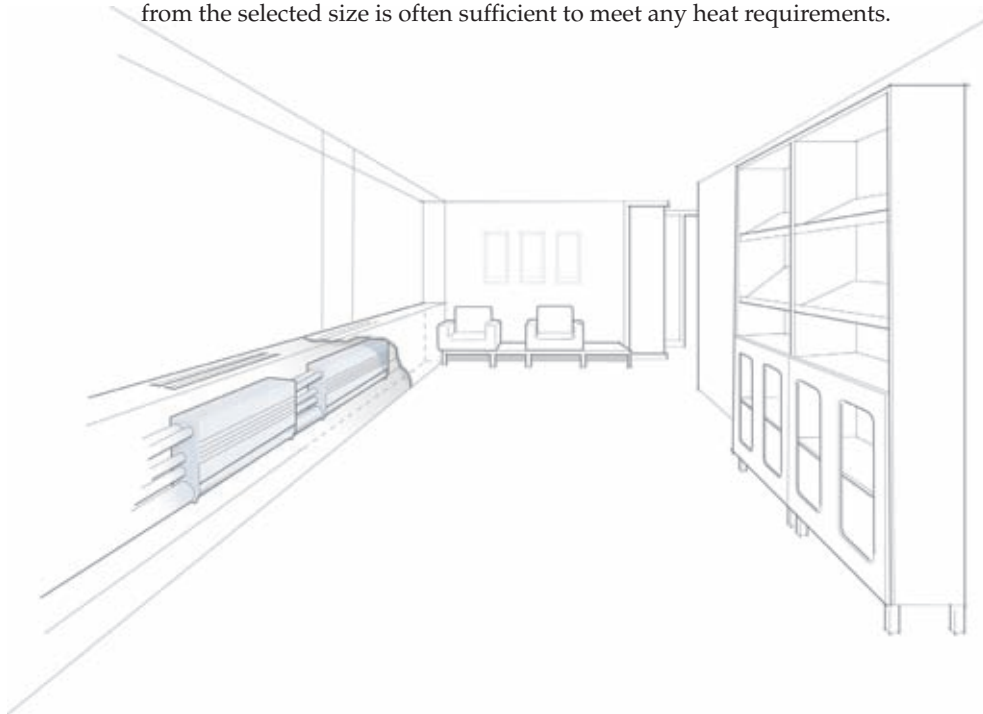



Energy-efficient systems

SFP values and VAS classes

To gain an idea of how energy-efficient a ventilation system is, you can calculate the unit's SFP (Specific Fan Power) value.

The Swedish Indoor Climate Institute (SIKI) has published guidelines and instructions describing various VAS classes. In the document *klassindelade luftdistributionssystem, R2*, ventilation is divided into different VAS classes depending on the SFP of a system. VAS 1500 means a system with an SFP of max. 1.5 kW/m³/s.

SIKI's documents A2 and R2 define three "standard classes": VAS 1500, VAS 2500 and VAS 4000. With VAS class "X", the opportunity is provided to define requirements that fall between the other classes. To be able to determine which VAS class the system falls under, the planner has to calculate the SFP value, which is specified in kW/(m³/s).

The specific fan power output, SFP, for an entire building is equal to the sum of the power supplied to all fans in the building, expressed in kW, divided by the building's largest projected measurable supply or exhaust air flow in m³/s. (Note: not outdoor air or extract air flow.)

Specific fan power output for an entire building

$$SFP = \frac{\sum P_{\text{mains}}}{Q_{\text{max}}}$$

SFP = the building's specific fan power output requirement

P_{mains} = the total of the supplied electrical output to all building fans, kW

Q_{max} = the building's biggest projected measurable supply or exhaust air flow, m³/s

For CAV systems, the SFP flow at 100% of the projected air flow is applicable, while for VAV systems, the SFP flow at 65% of this air flow is applicable. The pressure drop which the fans have to overcome includes pressure drops in air distribution systems and other devices such as air conditioning units, filters and heat recovery devices. System effects must also be included. For the system to fall into VAS class 1500, for example, the calculated SFP value must not exceed 1.5 kW/(m³/s).

VAS class	SFP
Ventilation Air conditioning System	Specific Fan Power
VAS 1500	= 1.5 kW/(m ³ /s)
VAS 2500	= 2.5 kW/(m ³ /s)
VAS 4000	= 4.0 kW/(m ³ /s)
VAS x	= x/1000 kW/(m ³ /s)

SFP_v value

Above is a description of how the SFP value for an entire building is calculated. A building often consists of a number of different elements, each of which is served by separate air conditioning units. To allow you to see during planning work whether a specific unit meets the desired subrequirements for energy efficiency, *föreningen V* (Föreningen Ventilation-Klimat-Miljö) defined in *V-skrift 1995:1* a supplementary SFP value with the index "V".

Specific fan power output for heat recovery unit with supply air and exhaust air fans

$$SFP_v = \frac{P_{\text{mains TF}} + P_{\text{mains FF}}}{Q_{\text{max}}}$$

SFP_v = the heat recovery unit's specific fan power output requirement, kW/(m³/s)

P_{mains TF} = the supply air fan's fan power output, kW

P_{mains FF} = the exhaust air fan's fan power output, kW

Q_{max} = the unit's greatest supply or exhaust air flow, m³/s

Rule of thumb

1 Pa costs € 0.27/m³/s and year

Operating time = 12 hours/day

Cost of electricity = € 0.05/kW

Motor output = 5 kW, m³/s

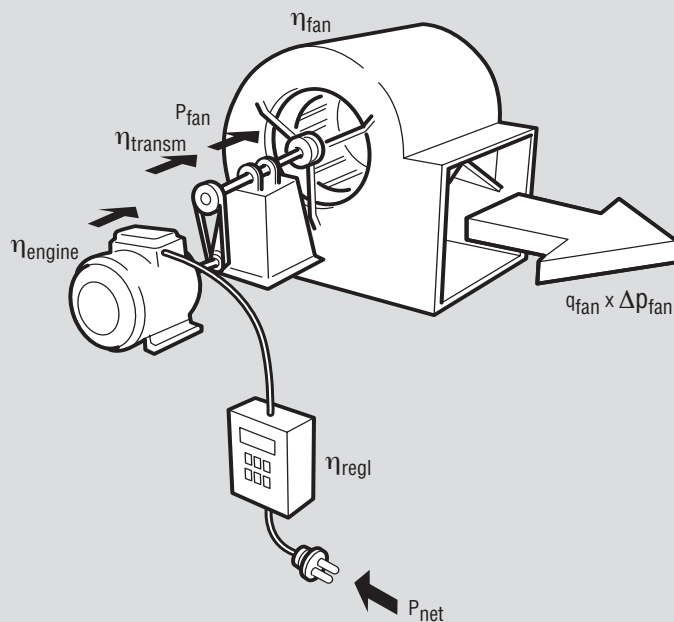

Calculation of fan power output, P_{mains}

$$P_{mains} = \frac{q_{fan} \times \Delta p_{fan}}{\eta_{fan} \times \eta_{transmission} \times \eta_{motor} \times \eta_{regulator} \times 1000}$$

η = efficiencies for fan, transmission, motor and regulation equipment (see Fig.).

For units with rotary heat exchangers, leakage and cleaning flow must be included in the calculation of the mains output to the exhaust air fan motor.

Any throttling required on the exhaust air side to achieve the correct pressure balance and leakage direction in the unit must also be included.

Life Cycle Cost, LCC

THE SUM OF INVESTMENT COSTS FOR AN ITEM OF EQUIPMENT AND THE CURRENT VALUE OF THE ENERGY, MAINTENANCE AND ENVIRONMENTAL COSTS OVER THE SERVICE LIFE OF THE EQUIPMENT.

The Association of Swedish Engineering Industries has published "Kalkylera med LCC — Ekonomisk hållbar upphandling av energikrävande utrustning" for building-related equipment. The purpose of this document is to provide a specific aid for clients, consultants, contractors and suppliers to streamline energy consumption.

Here, there is a form system indicating how the Life Cycle Energy Cost, LCC_E , is to be calculated for an item of equipment, and how this is to be combined with the investment cost. Maintenance and environmental costs are not included in this combination. Fläkt Woods has a built-in LCC_E module in its product selection program in which various unit functions can be compared and optimised to give the lowest LCC_E cost.

In a normal air conditioning system, operating costs account for about 90% and investment costs for less than 10% of the total life cycle cost over 20 years. Therefore, energy-efficient systems are of crucial significance for overall economy. If requirements for a specific LCC_E cost have been set for a system and guaranteed by the supplier, it must be possible to check this directly by means of measurement during the final inspection. In the case of an air conditioning unit with a heat recovery unit, the air flows, output requirements and temperatures can then be measured so that an actual SFP value and temperature efficiency can be determined. From this data, we then calculate the LCC_E cost and compare this with the requirement.

If the installation fails to meet the requirements, the supplier may be liable to pay compensation. If the installation is more energy-efficient than was required, the supplier may receive a bonus.

Electricity-efficient fans

To achieve a low VAS class — i.e. a low specific fan power (SFP) in a system — you first have to make sure that the pressure drops in units and distribution systems are kept low as the use of electricity is directly proportional to the pressure increase in the fans. Of course, it is important for the efficiencies of the fan, the motor, any transmissions and regulation devices to be as high as possible as power consumption is inversely proportional to these efficiencies.



Fan types

SMALL AIR FLOWS < 0.5 M³/S

Radial fans with forward-bent blades are used for the smallest air flows, even though the efficiency of this fan type is relatively low. This is because this fan type can provide a sufficient pressure increase at moderate speeds. Fans with backward-bent blades must often be run at impractically high speeds in this range.

MEDIUM AND LARGE AIR FLOWS < 0.5-10 M³/S

The two most common fans in the ventilation unit are: *the plug fan and the double inlet radial fan with backward-bent blades*. The plug fan consists of a radial impeller direct located on a motor shaft. The fan has no spiral casing; instead, it utilises the unit as a pressure chamber. The plug fan has low vibration and is suitable for hygiene applications thanks to its easy access. The double inlet radial fan has backward-bent blades which result in high efficiency, and the double inlet implementation makes this fan compact, a feature necessary for it to be incorporated in units.

LARGE AIR FLOWS > 10 M³/S

Plug fans are suitable for large air flows, and in the case of extra large air flows, two fans can be placed side by side. An alternative solution is to use *axial fans with postpositioned guide rails*. By varying the hub diameter, the number of blades and — above all — the blade angle, you can cover a large working range even for constant asynchronous motor speeds.

Transmissions

BELT TRANSMISSION OPERATION

Belt transmission operation makes it possible to implement arbitrary fan speeds in steps of 6% below, within and above the asynchronous speeds, and is available for ordinary three-phase motors directly connected to the network. The belt transmission also makes it possible to select an appropriate number of poles for the motor. Finally, the belt transmission provides lots of freedom when it comes to deciding where the motor is to go: an important point when fitting in a unit.

V-BELT TRANSMISSIONS

V-belt transmissions are the most common kind. The biggest advantage is the ready accessibility of the belts and discs. The biggest disadvantages are their need for maintenance with post-tensioning, their limited service life, and the fact that they give off dust. Efficiency at outputs in excess of 3 kW is approx. 95% but may be considerably poorer at lower outputs.

FLAT BELT TRANSMISSIONS

Modern flat belts are maintenance-free, have a long service life (approx. 5 years), are very efficient (approx. 98%) and generate an insignificant amount of dust.

MICRO-V OR RIBBED FLAT BELTS

MICRO-V or ribbed flat belts are a kind of halfway house between V-belts and flat belts. They have the disadvantages of the V-belt transmission, with post-tensioning, wear, restricted service life, maintenance and dust emissions, but they are slightly more efficient than V-belts.

Direct operation

Direct operation means that the fan impeller is mounted directly on the motor shaft or — as with external rotor motors or plane anchormotors — is mounted on the rotary outer element of the motor. The advantage is the lack of transmission elements and their maintenance, and the fact that transmission losses are prevented completely. A low vibration level is an important advantage. The disadvantage is that the speed almost always has to be regulated using a speed regulator when radial fans are fitted in order to achieve the required working point. The losses in this equipment are often higher than in a belt transmission. Direct operation cannot be used on double inlet radial fans, except in the case of very small fans. The long fan shaft which would then be required would end up critical bending oscillation. Axial fans are constructed with different blade angles in order to achieve the right pressure and flow.

Highly efficient electric motors

The EU and the European manufacturers' organisation CEMEP have produced a classification and labelling system for low-voltage AC motors according to efficiency classes. Up to now, this classification applies to 3-phase asynchronous motors, 2 and 4-pole, 50 Hz, 400 V and with a nominal output of between 1 and 90 kW. There are three efficiency classes — eff1, eff2 and eff3 — for these motors. Class eff1 includes the most energy-efficient motors. The energy authority has a list of the requirements made of motors in the various classes.

The diagram shows a general overview of the classes.

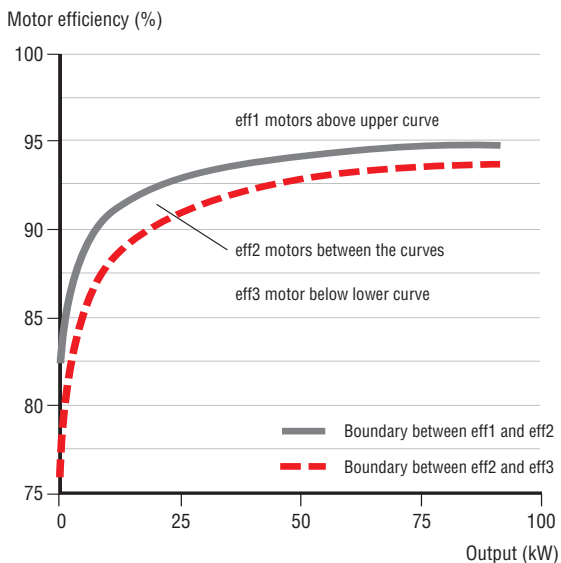

Regulating devices

The cheapest, simplest way to regulate the air flow through a fan is to change the resistance, i.e. to throttle the air flow using a damper. However, this method is inexpedient in terms of the energy used. Another method is to control the flow using adjustable guide rails in the fan intake, which would reduce the air flow and ensure fewer losses than is the case with damper regulation. The most energy-efficient way of controlling fan operation is by means of continuous adaptation of the fan speed as required with the aid of a frequency inverter. Controlling the speed to suit requirements precisely can reduce the energy requirement by 50% compared with throttle regulation. The figure shows how the power require-

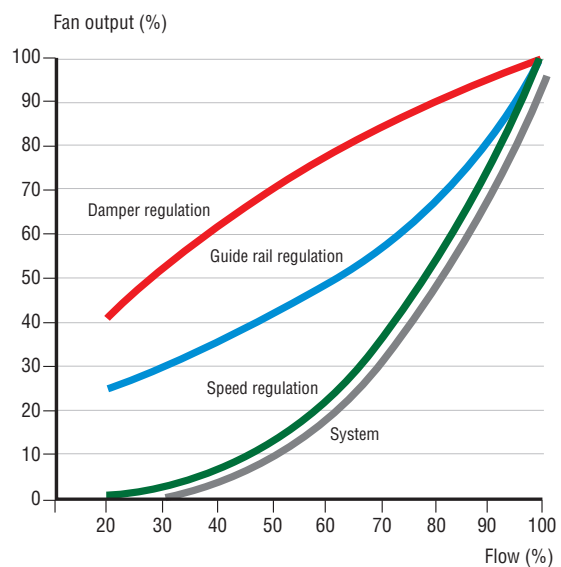

ment is dependent on the volume flow in the case of different regulation methods. To achieve maximum total efficiency, the fan, motor and frequency inverter must all be co-dimensioned. In most cases, maximum efficiency is achieved when the motor is run oversynchronously, i.e. at 50–85 Hz. Asynchronous motors with a built-in frequency inverter, known as integral motors, are also used. These offer more or less the same efficiency as asynchronous motors, with a separate frequency inverter. The advantage of this is simpler installation, particularly in view of EMC requirements. What are known as EC motors have been launched in the lower output range of late. These are permanently magnetised DC motors without brushes, controlled by an electronic unit. These are highly efficient — particularly in the case of speed regulation. All fan speed regulation is limited by the fans' "pump ranges".

For appropriate regulation devices in the respective cases, see also the Fläkt Woods product catalogue.

Control and regulation equipment

For an air conditioning system to function correctly, it requires not only products, but also some form of electronic control and regulation system. The function of the control system is to control, regulate and monitor functions and components so that the intended climate is achieved.

Traditionally, a central control cabinet is constructed which contains all the automatic devices required for the entire system. With construction times becoming quicker and quicker, the trend is for control and regulation components to be integrated into the products right from the outset, and then the various products are just linked together at the construction site.

DEMAND CONTROLLED VENTILATION (DCV)

DCV is based on ventilation of the room using the right air flow for the right occasion. The ventilation flow is controlled by the load and presence in the room. Used correctly, this provides high air quality while at the same time saving energy. DCV can be applied to areas which vary widely in terms of load and presence, such as conference rooms, board-rooms, cafeterias, etc. Surveys have shown that the presence level is 25–60% lower than what has been dimensioned.

This means that with the help of DCV, the air flow can be reduced: this can also result in heating and cooling requirements reduced by 10–30%.

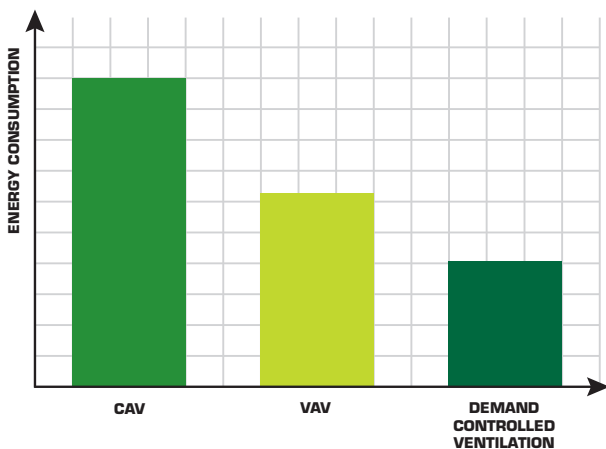

CAV AND VAV SYSTEMS

For CAV systems, frequency inverters are often used to maintain the flow independently of changes in pressure drop which occur when filters are contaminated, for example. Flow regulation is an appropriate alternative in this case. For CAV systems with additional zones, we recommend frequency inverter operation with pressure regulation.

Pressure regulation is used for VAV systems, where appropriate with flow-compensated supply or exhaust air in order to ensure balance in the system.

Frequency inverters are also an excellent tool for adjustment of the flow, and can eliminate the need to switch the belt transmission in order to change the air flow. However, this may compromise optimum efficiency to a certain extent.

REGULATION METHODS

Selecting the right temperature regulation.

• Supply air regulation:

Premises with an individual room climate, post-treatment with Fan Coil, VAV etc., for example, in the case of a collective room climate where it is not possible to set a representative room sensor. Premises with large air replacements and small contributions from internal thermal loads.

• Room regulation:

Used where the unit serves larger rooms. Premises with large internal increased heat supplies.

• Exhaust air regulation:

Premises where it is not possible to place a room sensor and where the average temperature of the exhaust air constitutes good mean value. Premises where you wish to attain a very small temperature deviation.



DCV — Demand Control Ventilation

Demand controlled ventilation is an effective way of saving energy and at the same time ensuring an optimum indoor climate in which people can feel good and do a good job. The basic principle involves adapting the degree of ventilation according to the load and contamination level of the room. In practice, this can be achieved by supplementing the room regulator with sensors for presence, carbon dioxide and VOCs (Volatile Organic Compounds).

FUNCTION

The presence sensor detects the presence of anyone in the room. When the room is empty, the room regulator reduces the ventilation flow to a preset minimum level, and a signal to increase ventilation is given only when the presence of a person in the room is detected. This method avoids unnecessary ventilation and large amounts of energy can be saved. Experience has shown that potential savings may amount to 50%. The relatively high air flows in a VAV system ensure good air quality (IAQ) in the room in most cases.

The amount of carbon dioxide in the room air is an indicator of whether the room's air change is sufficient and

can therefore be used to control the ventilation according to the current load in the room. This is particularly effective on premises where the load — i.e. the number of people in the room — varies widely. School halls and conference rooms are examples of such premises. If the carbon dioxide content is lower than 1000 ppm, the air change in most cases is sufficient for the people on the premises.

On sparsely populated premises, such as open plan offices, the building and what actually goes on there are more the source of the contamination than the people on these premises. Volatile organic compounds (VOCs) coming from (emitted from construction materials, interior fittings and electronic units, among other things, may cause ill-health in people spending time in the building. VOC sensors which increase the ventilation if the concentration of VOCs exceeds a preset limit can rectify this and thus contribute towards a sense of wellbeing and high capacity for performance among the people working on the premises. To achieve this, a greater air flow than that specified in standards and regulations is required in most instances.

COMMUNICATION — TOPOLOGY

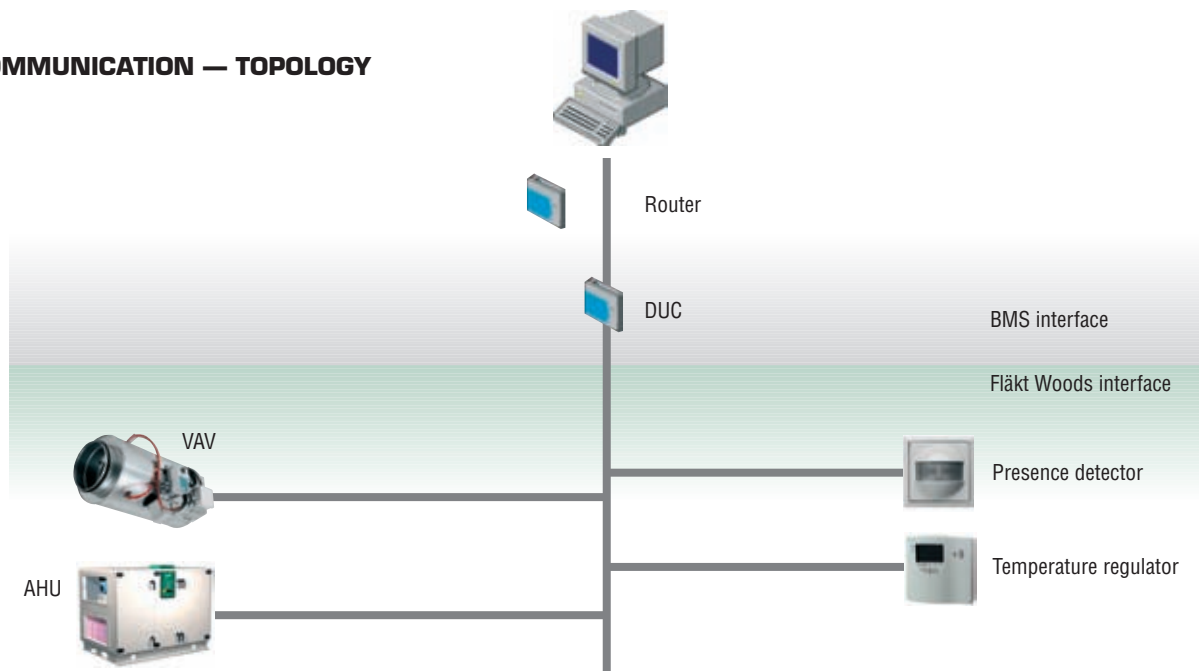

COMMUNICATION

A modern building automation system should be structured using standardised, open communication. This provides the opportunity for integration of devices of various makes at a low cost, while at the same time focusing on user friendliness and functionality, and allowing the system to be customised to suit the requirements of the customer. Fläkt Woods control equipment is able to handle the following open communication options.

- *BACnet*

The regulator can be provided with communication cards for integration in BACnet systems. BACnet is an open world standard, produced especially for building automation. BACnet is connected via a TCP/IP network.

- *OPC*

The regulator can be provided with a card with an OPC server for integration in monitoring systems which can handle OPC. OPC is an open industrial standard which uses a common interface to simplify integration of various products into one and the same system. OPC is connected via a TCP/IP network.

- *LonWorks*

The regulator can be provided with communication cards for connection to LonWorks. Loncards are provided with automatic mailing of all SNVTs, so facilitating simple commissioning. LonWorks cards are connected via the Lon network.

- *Modbus*

The regulator can be provided with communication cards for connection to Modbus-DUC, or alternatively to Modbus monitoring systems. Modbus is an open industrial de facto standard and connected via RS 485 or TCP/IP. The Modbus card can be configured as either a master or a slave.

- *Web communication*

Several suppliers of regulators are now offering regulators with a built-in webserver, which means that no specific monitoring program is required. Just a standard web browser on any computer in the network (TCP/IP) will do.



Fire protection systems

WHAT HAPPENS IN A FIRE

When there is a fire, overpressure is created in the room with the fire. The air expands when it is heated and looks for paths out to other rooms where the pressure is lower. Toxic gases from the fire which are harmful to humans follow the hot air. The fire continues to develop until the oxygen or the fuel runs out. The overpressure is at its greatest just at the point before the windows break in the room where the seat of the fire is located. The windows shatter and this results in natural pressure relief in the room, reducing the risk of combustion gases spreading.

WHY VENTILATION FIRE PROTECTION?

In buildings constructed to a modern standard, there are ventilation ducts which link together various fire cells. These provide an excellent escape route for the fire flow, but combustion gases must not be allowed to spread to areas where there are people. To limit the damage to people and property, it is important to have active protection to prevent fire and combustion gases from spreading through the building. Good fire protection consists of a number of components which interact, but even so these are no stronger than their weakest link. Ventilation fire protection must be taken into account in order to fulfil the requirements for personal safety contained in building standards.

FINANCE

Ventilation fire protection is always costly. Regardless of whether you choose solutions involving costs for planning or costs for technical equipment, ventilation fire protection must be included in your calculations. Your fire protection will pay for itself only if there is a fire involving only minor damage to property and people. To find a cost-effective solution, you need to analyse the building, what goes on there, and the priorities. What is important to the client? How will the building be used? If this stage is executed correctly, and ideally early on, the system solution for ventilation fire protection will be the best one possible in terms of both cost and safety.

WHAT IS THE MOST EFFECTIVE SOLUTION?

No one solution is ideal for all instances. Different companies have different protection targets: there are different technical options for different geometries and ventilation system, and so forth. The most effective ventilation fire protection is the one best adapted to suit the conditions. However, systems with fire/combustion gas dampers always meet demands for protection against the spread of fire and combustion gases.

Definitions

FIRE

Fire is an oxidation reaction which develops heat. During this reaction, carbon dioxide, nitrogen oxides and hydrogen cyanide are formed. These substances are present in the combustion gases and are harmful to humans.

FIRE FLOW

Fire flow is a term for the expansion that takes place when the air heats up. The faster the temperature increase, the higher the fire flow (l/s). Fire flow must not be confused with plume flow.

PLUME FLOW

Plume flow is the term for the volume of combustion gases developing from the fire (l/s). The size of the plume flow varies according to the materials.

FIRE DEVELOPMENT

Natural fires develop at different speeds depending on the propensity of the material to burn.

STANDARD FIRE, ISO 834

Standard fire is a standardised fire process. The standard fire has been produced to allow building elements to be tested and dimensioned in a comparable manner. The links are described below:

$$Tt - T0 = 345 \log_{10} (8t + 1)$$

Tt = fire cell's gas temperature in °C at time t .

$T0$ = fire cell's gas temperature in °C at time $t = 0$.

t = time in minutes following the start of heating

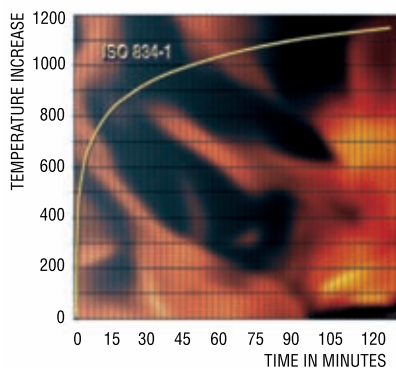

FIRE PROTECTION DOCUMENTATION

Fire protection documentation describes fire protection for new buildings and buildings being renovated. The fire protection documentation must meet the requirements laid down in the building regulations.

BUILDING REGULATIONS

Building regulations of the National Board of Housing, Building and Planning, regulation from the National Board of Housing, Building and Planning in which functional requirements and detailed requirements are described in respect of fire protection.

FIRE CELL BOUNDARIES

Fire cell boundaries separate different operations, floors, technical areas, etc. in order to limit the extent of the damage in the event of a fire. Fire cell boundaries must be compliant with EI 30/60/90/120/240.

EI

Building elements must comply with sealing requirements (E) and insulation requirements (I) under the influence of a standard fire over 30/60/90/120/240 minutes. The insulation requirement (I) means that the temperature increase (DT) on the side not subject to the fire will amount as a maximum to 140 °C (mean temperature) and 180°C (spot temperature). As there must be compliance with this function, it is understood that there is also a bearing capacity requirements for the building element. Fire cell requirements are based on the operations and the building class.

Example:

EI 240: Br1 building, fire load >400 MJ/m².

EI 120: Br1 building, fire load 200–400 MJ/m², some stores.

EI 60: Br1 building, fire load 200–400MJ/m²,
all accommodation.

EI 30: Br2 and Br3 buildings.

E30: Smoke cell boundary on care premises

BUILDING CLASSES

Buildings are divided into different classes depending on the number of floors, operations and size. Building classes are Br1, Br2 and Br3. Br1 specifies the most stringent requirements for bearing capacity and separating structures. Br3 specifies the least stringent requirements. Advice in accordance with BBR 5:21, parts of buildings. See the facts box on the right.

System solutions for fire protection in ventilation

DIVISION OF BUILDINGS IN ACCORDANCE WITH BBR 5:21

Buildings with three or more floors should be included in class Br1. The following buildings with two floors should be included in class Br1:

- Buildings designed for sleeping people who do not have good local knowledge
- Buildings designed for people who have little chance of escaping to safety on their own.
- Buildings with meeting rooms on the first floor

The following buildings with two floors should be included in class Br2 as a minimum:

- Buildings with more than two accommodation apartments where there are workrooms or dwelling rooms at attic level.
- Buildings with meeting rooms on the ground floor.
- Building with fire cells larger than 200 m².

Buildings with a floor housing a care facility (apart from preschool) or meeting room should be included in class Br 2. Other buildings may be included in class Br 3 as a minimum.

*)NOX = Nitrogen oxide
HCN = Hydrogen cyanide

There are a number of different requirements laid down in the building regulations for ventilation systems relating to fire protection. These requirements are set mainly when ventilation systems serve or pass a number of fire cells.

Ventilation ducts must be laid and designed so that they do not give rise in the event of a fire to ignition outside the fire cell in which they are located. Nor may the ventilation system contribute towards the spread of combustion gas between fire cells. Air conditioning installations which pass across fire cell boundaries must be designed so as to maintain the capacity to keep the fire cells separate.

The materials in ventilation systems must be non-flammable so that they do not contribute to the spread of fire and combustion gas.

THERE ARE ESSENTIALLY THREE DIFFERENT WAYS OF MEETING THESE GENERAL REQUIREMENTS:

- Separate ventilation systems for every fire cell
- Systems which shut the combustion gases in the fire cell
- Systems which draw the combustion gases out of the building



Product option programme



EXSELAIR

Program for selection of devices, chilled beams, fan coils and perimeter wall units. This is a web-based program which is updated regularly without the user having to download and install updated. The program includes:

- Technical data
- 3D models
- Flow patterns in 2D and 3D
- Dxf files can be exported to CAD software
- Installation, adjustment and maintenance instructions
- Heating and cooling requirement calculations.



ACON

Program for the section and planning of air conditioning units. This is a web-based program which is updated regularly without the user having to download and install updated. The program effectively gives the user all the information and support required for good planning:

- Product dimensions
- Noise data
- Efficiency
- LCC
- Delivery time
- Dxf and Dwg files can be exported to CAD software.
- Support is available for Autodesk's In-Drop.
- Documentation always up to date



FAN SELECTOR

Program for selection of axial fans. This program can be run both on the web and independently. The software is updated regularly on the Internet.

The program includes:

- Product dimensions
- Noise data
- Efficiency
- LCC
- Delivery time

EPBD

The EU has set a target for reducing energy consumption as a result of the Kyoto Protocol. As of 2006, all EU member states will adopt new building regulations which take into account the energy performance of buildings. The aim of the EU's energy directive is to reduce energy consumption by 22% by 2010. The 160 million buildings in Europe consume more than 40% of European energy. This is why the EU has made a decision on an energy directive, known as the Energy Performance of Buildings Directive, or EPBD. In Sweden, the National Board of Housing, Building and Planning has compiled new building regulations in the book *Regelsamling for byggande*, which came into force on 1 July 2006. The rules have been revised and adapted to comply with the targets laid down in the energy directive. The EU's energy directive essentially includes five elements which must be introduced:

- A methodology for calculation of the integrated energy performance of buildings
- Minimum requirements for the energy performance of new buildings
- Minimum requirements for energy performance for major renovations to/ alterations of buildings
- Energy declaration of buildings
- Inspection of heating systems, with boilers/burners and air conditioning systems, plus an assessment of heating systems more than 15 years old.



*Saving Energy,
Economy and the
Environment with
Fläkt Woods.*

Minimum requirements for energy performance

Regardless of the type and age of the building, the minimum requirements for the energy performance of buildings must not involve impairment of the indoor climate or the function of the building.

Lagen om Energideklarationer (Energy Declaration of Buildings Act)

The aim of the energy declarations is to acquire information on the energy performance of a building and recommendations for cost-effective measures for reducing energy consumption.

The new Act means that buildings will be inspected, and certain details on buildings' energy consumption and indoor environment will be stated in an energy declaration when they are sold or let, or when new buildings are constructed. The owner will have the opportunity to reduce the costs involved with energy consumption by implementing the measures specified in the energy declaration.

The energy declaration must be compiled by an independent expert with a specialist knowledge of energy consumption and the indoor environment.

The environment and quality

Life Cycle Assessment — LCA

An important part of the development and manufacturing process is assessment of the effects of the products on the environment over their entire life cycle: including raw materials, manufacture, usage, phaseout and recovery. The intention is to find the most environmentally friendly combinations so that the adverse influence on the environment can be limited.

The life cycle assessment for fans and units shows that energy consumption for running the fans over the service life of the products has the greatest impact on the environment. To be able to select energy-efficient fans, see the section entitled *Energy-efficient systems* — this contains information on SFP value, VAS class and LCC. Information from the life cycle assessment also provides a basis for the environmental declaration.

Environmental declaration

The Ecocycle Council for the Building Sector has established what should be included in a building commodity declaration, and Föreningen Ventilation-Klimat-Miljö has worked on the basis of this to prepare a template for the environmental declaration of ventilation products. The environmental declaration is prepared by the manufacturer and contains factual information on the product which is easy to interpret. This information includes everything from materials used, production, distribution, usage, phaseout and recovery. It also provides information on the manufacturer's

quality and environmental status. The intention behind the environmental declaration is to make it easier for customers to compare different products and be able to select the ones with a small adverse impact on the environment.

Environmental labelling

Criteria for environmental labelling are not available for ventilation products.

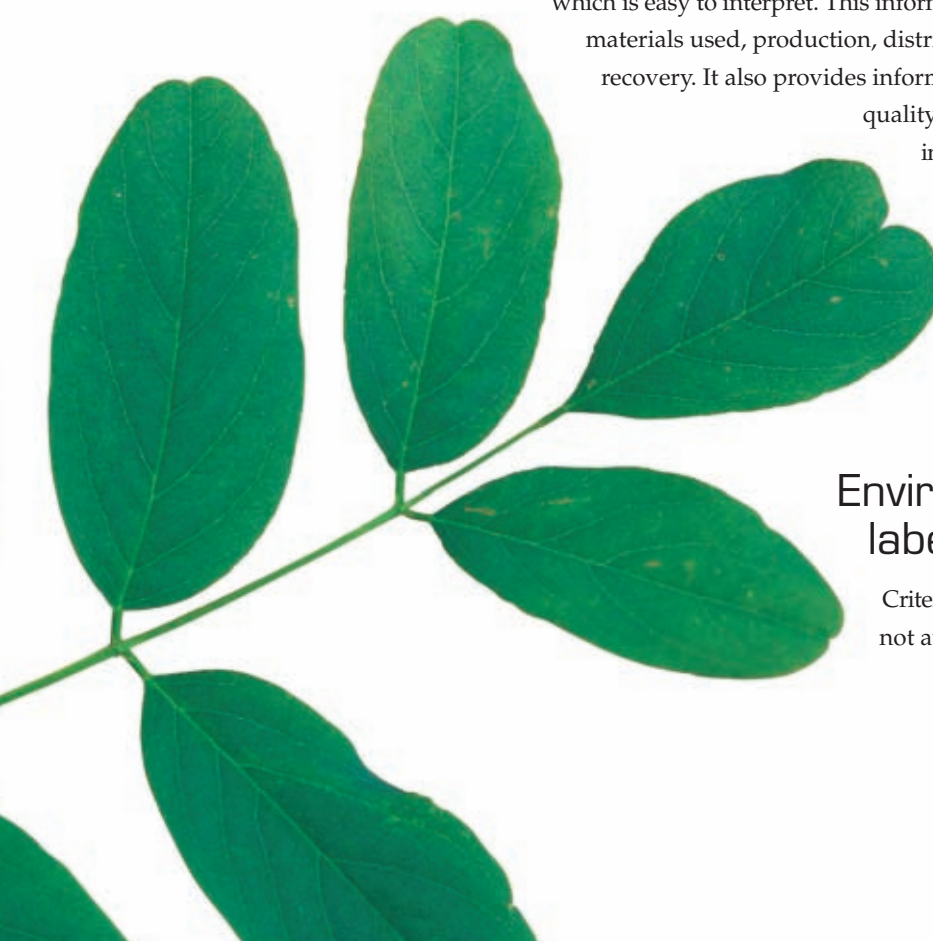

Eurovent

This is an independent third-party organisation which carries out testing of cooling and ventilation units. For a product to obtain a Eurovent certificate, it must be possible to verify the details given by the manufacturer in its technical documentation by means of testing. By selecting products with a Eurovent certificate, clients and planners can be sure that the data provided to them is correct.



CE labelling

The EU has prepared a number of directives intended to enhance safety for both humans and the environment. At present, the Machine Directive, Low Voltage Directive and EMC Directive apply to ventilation systems. When products are designed and manufactured, these requirements have been taken into account; and complete air conditioning units fitted with electrical, control and regulation equipment are CE-labelled. For other products, the manufacturer prepares a declaration stating that the EU directives have been taken into account.

The system may then be CE-labelled.

ISO 9001

This standard specifies requirements for how a quality assurance system should be structured, but it does not include product requirements. The quality system is an aid for streamlining operations and assuring quality levels and delivery reliability.

ISO 14001

This standard specifies requirements for how an environmental management system should be structured. The environmental management system ensures that the manufacturer has control of its environmental operations and is working constantly to reduce its adverse impact on the environment, helping to economise on our natural resources.

EMAS (Eco Management and Audit Scheme)

EMAS is the EU's environmental management and audit scheme, which specifies demands for an environmental management system in accordance with ISO 14001, as well as a public environmental audit. The environmental audit includes details on the manufacturer's operations, assessment of important environmental issues and key data for the consumption of raw materials and energy. The environmental audit is reviewed and approved by an accredited environmental inspector. EMAS registration takes place at the Swedish Environmental Management Council.



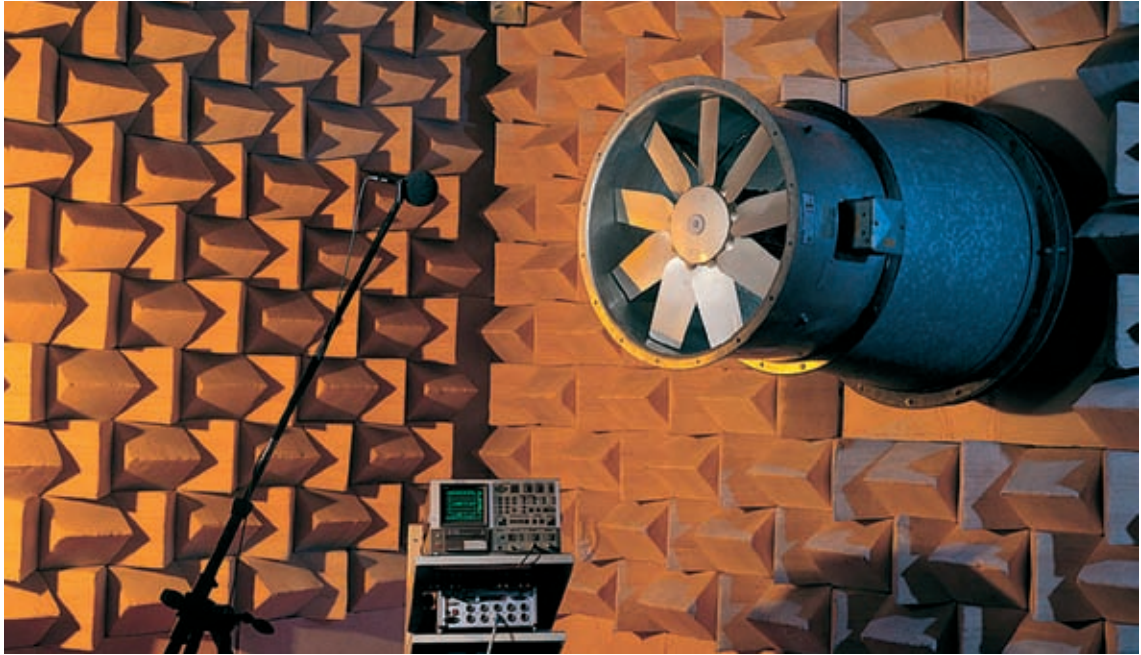

Noise in air conditioning systems

General information on noise

An even, pleasant noise level, temperature and air rate are the most important requirements for a good indoor climate. Most of the climate problems that may occur indoors can be resolved by means of a correctly dimensioned climate system. To achieve this, careful planning work has to be done, and the technical noise calculations are an important part of this.

Apart from fans and units, dampers and other devices are the loudest sources of noise in an air conditioning system. The noise of the fans can spread to the premises via the building carcass, for example, or via the actual duct system. This means the noise attenuation measures need to be implemented. In the supply air system — and in the exhaust air system as well — silencers often have to be placed at fans and dampers.

For a device, the need for a reduction in noise can only be met by changing the device type, size, etc.

□ FLÄKT WOODS RECOMMENDS

Note that a large unit will reduce the need for noise attenuation, as well as providing better operating economy.

Noise level calculation

Calculating with noise

Calculating noise levels in an air conditioning system is intensive, time-consuming work. Therefore, we will show you here a simplified way of doing these calculations where any duct attenuation has been left out. Fläkt Woods recommends the following procedure for calculation work:

- 1 Draw a simple sketch showing the structure of the climate system.
- 2 To facilitate the noise calculations, it is application to compile the components of the system in a table. Start with the fan and note the components in the direction of the air. (See the table on page 114.)
- 3 Do the calculations, starting with the noise data found in catalogue material from Fläkt Woods.
- 4 What was the result? If you get a value that exceeds your requirements, go back in your calculations to see where in the system the greatest additional noise is. It is a good idea to attenuate as close to the noise source as possible.

You also have to take into account other noise paths, such as via the building carcass, and you should make sure that you notify your building consultant about these. A review of how to calculate noise for the machine room can be found in the table on page 121.

The example below shows the noise generation and noise attenuation of various system components, as well as how the noise pressure level is calculated. The noise requirement is assumed to be 35 dB(A), and the supply air noise pressure level must represent at most half of the permitted noise pressure level, i.e. $35 - 3 = 32$ dB(A). All noise effect and noise attenuation values are reported for just one octave band, 500 Hz, for the sake of simplicity. A complete description of the calculation example can be found in the table on page 120.

Frequently occurring quantities

Size	Unit	Description
L_{wt}	dB	Total noise effect level generated by a noise source
L_{wok}	dB	Noise effect level per octave band
L_{pok}	dB	Noise pressure level per octave band; the pressure that affects the ear. Is dependent on the room attenuation and distance from the noise source.
L_{wA}	dB(A)	Weighted noise effect level generated by a noise source
L_A	dB(A)	Weighted noise pressure level at a given room attenuation
ΔL	dB	Attenuation
ΔL_{wA}	dB(A)	Weighted attenuation

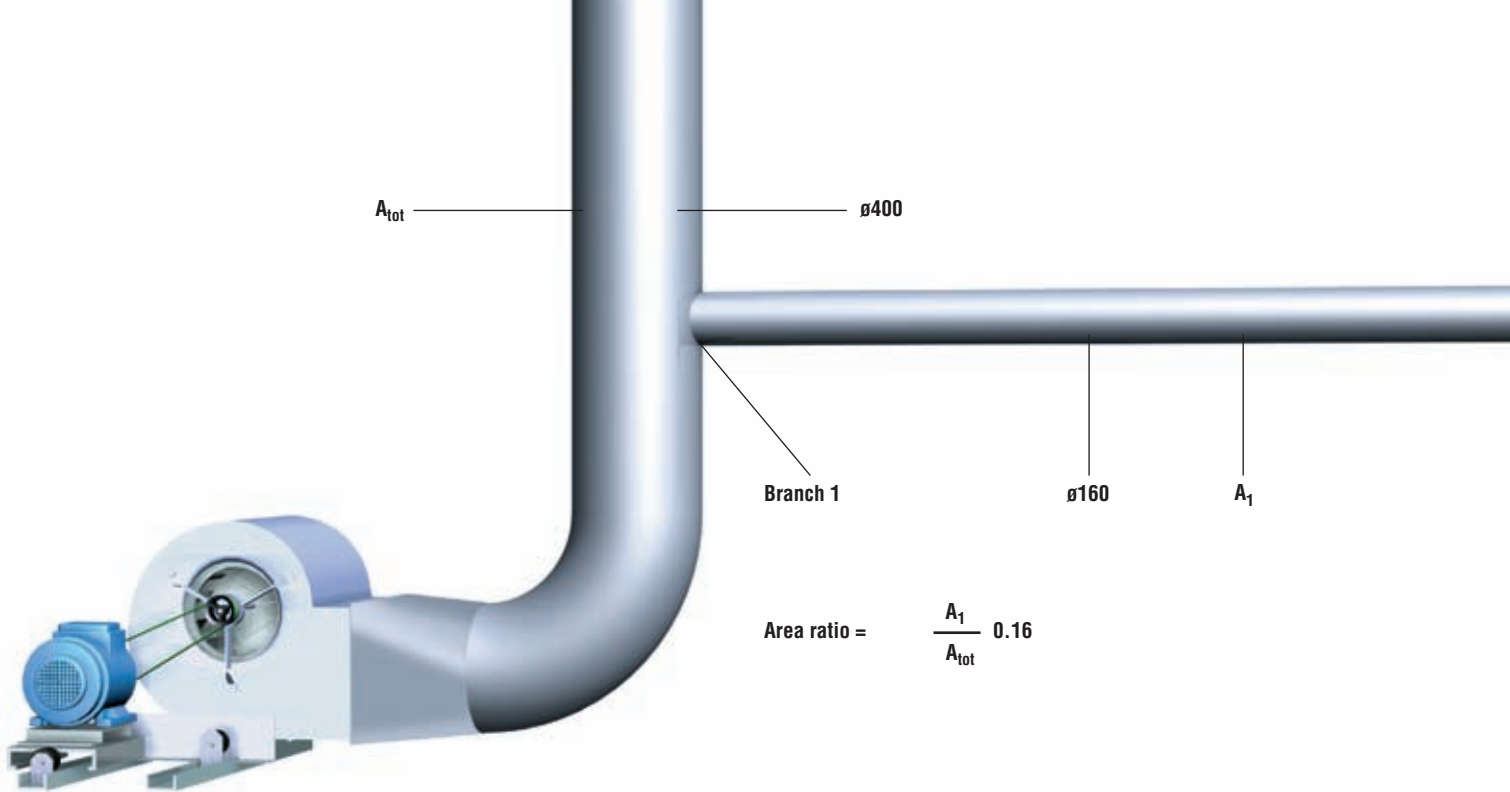

$$\text{Area ratio} = \frac{A_1}{A_{tot}} = 0.16$$

The noise effect level, L_{wA} , of 86 dB(A) is obtained from the fan diagram below for the supply air fan in this system.

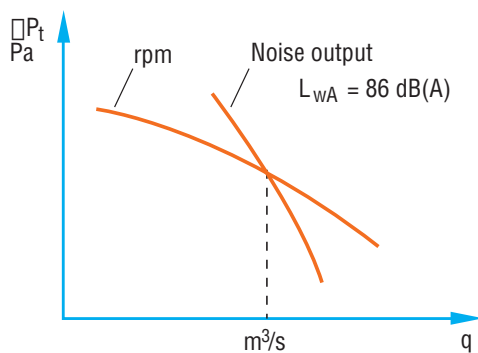

The noise effect level per octave band to duct, L_{wok} , is calculated by adding a correction factor according to the formula $L_{wok} = L_{wA} + K_{ok}$, K_{ok} as shown in the table below. In our example, the noise effect level for the frequency 500 Hz, $86 - 6 = 80$ dB.

Octave band, Hz	63	125	250	500	1000	2000	4000	8000
K_{ok}	-6	-4	-5	-6	-5	-6	-10	-17

The noise attenuation in an uninsulated circular bend is dependent on the frequency and the duct diameter. Attenuation for the 500 Hz band at a duct diameter of 400 mm will be 1 dB.

Attenuation for circular bend, dB

Diameter in mm	Octave band, middle frequency, Hz							
	63	125	250	500	1000	2000	4000	8000
130	-	-	-	-	-	1	2	3
140–250	-	-	-	-	2	3	3	3
260–500	-	-	-	1	2	3	3	3
510–1000	-	-	1	2	3	3	3	3
1010–2000	-	1	2	3	3	3	3	3

When a duct is divided, the noise effect is distributed in proportion to the areas of the ducts. The ratio of these, for branch 1, is 0.16, which in the diagram gives the value of the attenuation in dB — in this case 8 dB.

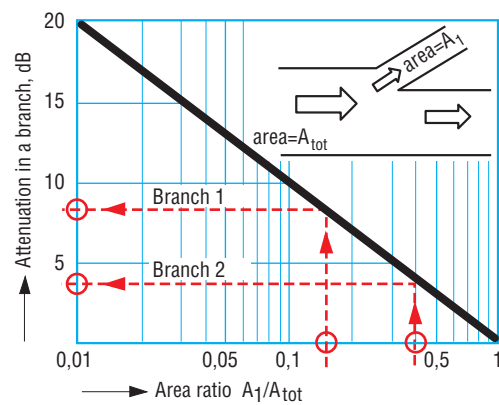

The duct system's self-generated noise may be omitted, provided that the air rates recommended are not exceeded.

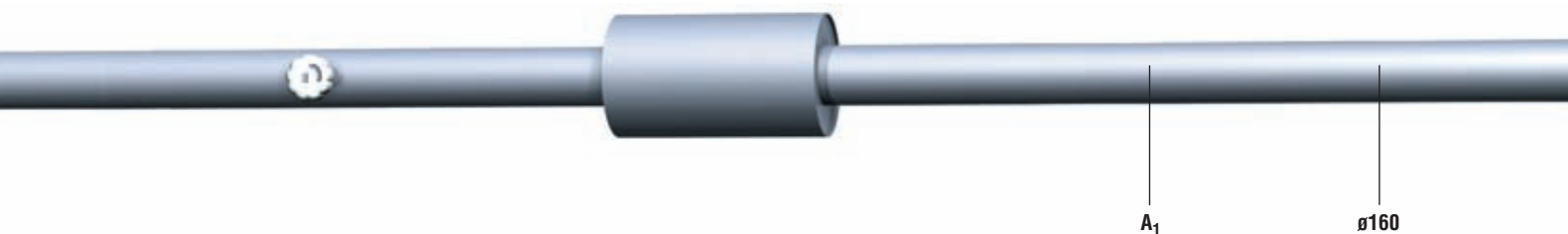

The damper's total noise effect level to the duct, L_{wt} , is converted to an octave band according to the formula:

$$L_{wok} = L_{wt} + K_1 + K_2$$

where the correction factors K_1 and K_2 are obtained from the adjacent tables for dampers BDEP-1. The noise effect level L_{wt} at 50 Pa and 4 m/s is 50 dB at a damper angle of 40° [equivalent to $L_{wA} = 44 \text{ dB(A)}$], and the two correction factors are read off at 0 and -13 database respectively. The correction factors K_1 and K_2 appear in the catalogue data and are dependent on the angle and size of the damper. The value of the noise effect level for a frequency of 500 Hz, according to this calculation, is $50 + 0 - 13 = 37 \text{ dB}$.

Noise effect level, dampers BDEP-1

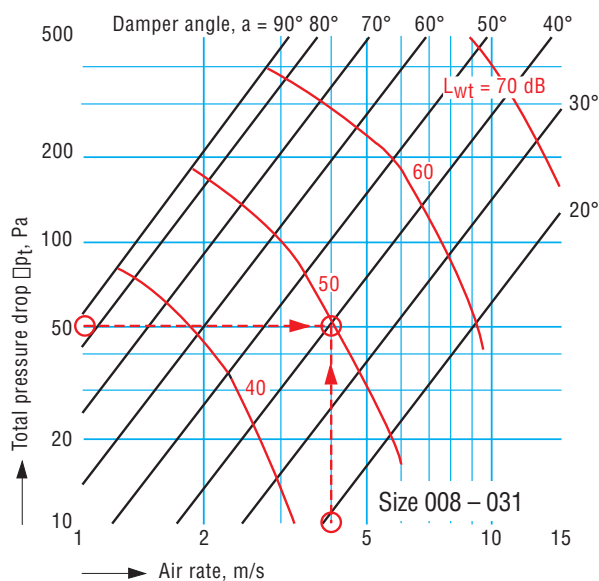

K_1

Size	008	010	012	016	020	025	031	040	050	063
K_1	-2	-2	-1	0	+1	+2	+3	+4	+5	+6

K_2

Size	Damper angle, °	Octave band, middle frequency, Hz							
		63	125	250	500	1000	2000	4000	8000
008-031	20	-4	-1	-10	-16	-18	-22	-26	-31
	30	-2	0	-9	-15	-17	-20	-24	-30
	40	-2	-1	-8	-13	-14	-13	-14	-21
	50	-5	-3	-6	-11	-12	-10	-11	-17
	60	-8	-5	-4	-8	-10	-13	-14	-19
	70	-8	-4	-5	-8	-10	-13	-15	-21
	80	-8	-4	-5	-9	-11	-14	-17	-23
	90	-9	-3	-6	-9	-11	-14	-18	-25

Silencers are connected in this case between the damper (noise source) and the supply air device, and can be connected in series for higher attenuation.

Attenuation in dB

Size	Octave band, middle frequency, Hz							
	63	125	250	500	1000	2000	4000	8000
BDER-30-016-030	0	4	6	9	11	18	18	13
BDER-30-016-060	2	5	10	18	23	33	30	19
BDER-30-016-090	3	8	16	27	36	47	37	21

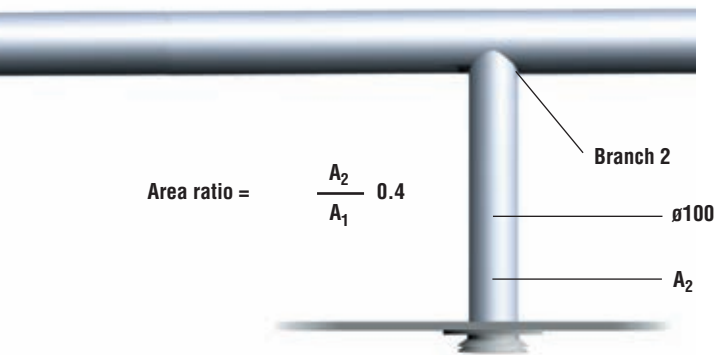

Calculation of the noise generated by the supply air and exhaust air devices takes place at normal air flow. Note that a device generates its own noise, and that the device's noise attenuation, L , determines the additional noise from the duct system. Subsequently you have to take into account both the device's self-generated noise and its noise attenuation. The noise level diagram for the device shows the supply air device's self-generated noise $L_A = 25 \text{ dB(A)}$.

Noise pressure level, supply air devices

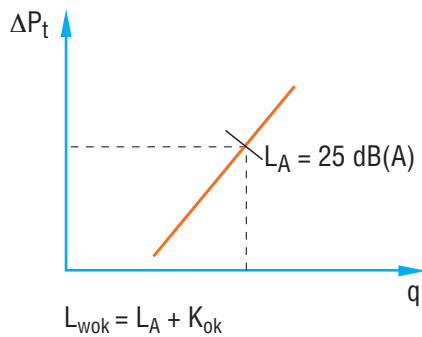

The device's noise effect level is calculated by adding a correction factor (Table A). This is 0 dB for the 500 band. The device's noise attenuation can be found in Table B. This is 13 dB for the 500 band.

Table A

Frequency, Hz	63	125	250	500	1000	2000	4000	8000
K_{ok} in dB	-6	-3	-3	0	-1	-1	-9	-12

Table B

Frequency, Hz	63	125	250	500	1000	2000	4000	8000
Attenuation L , dB	25	22	17	13	12	11	11	11

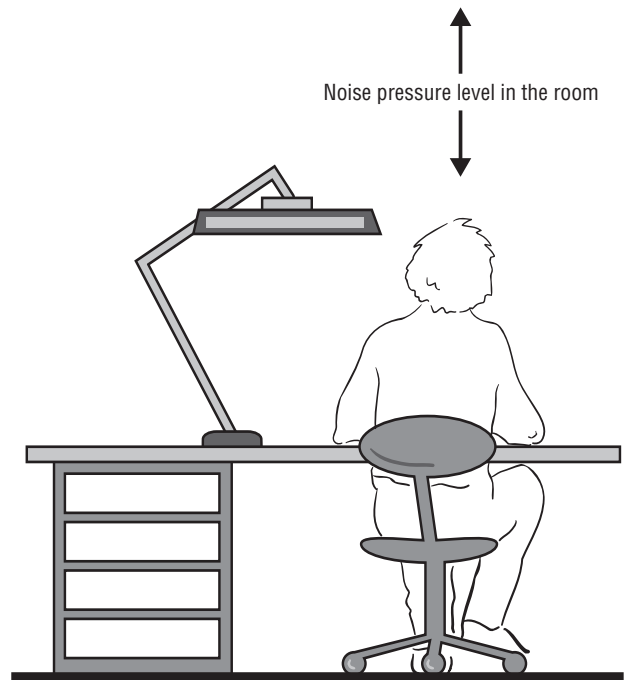

Addition of several noise sources

If there are two or more noise sources, these have to be added together using logarithmic addition. In our example, we encounter this on three different occasions:

- 1 Noise source in the duct system, e.g. damper. First, calculate the noise effect level before the damper and then add the damper's noise effect level. Use the diagram below.
- 2 Addition of the octave band values to dB(A) values, after correction for A filter. Here, too, we can use the diagram below and add one octave band at a time.

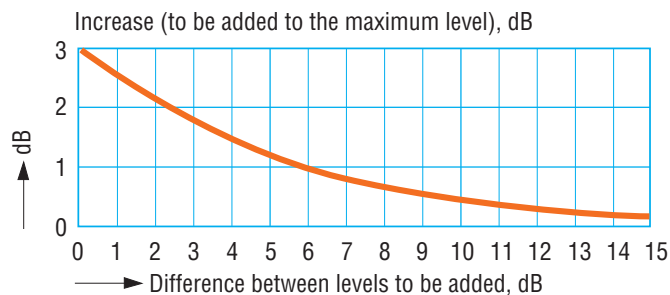

- 3 There are several noise sources in the room. Use the above diagram.

A RULE OF THUMB

It is worth remembering that two equal noise sources will increase the noise level by 3 dB, while three equal noise sources will increase the noise level by 5 dB.

Attenuation in the room

The attenuation in a room is dependent on the interior fittings and the number of people in the room, among other things. This is why it is difficult to provide anything other than guideline values for different room types. However, the following typical values can be used, albeit with caution:

Room type	Room attenuation, dB	Remarks
Modular office	4	–
Open plan office	12	With fitted carpets and ceiling absorbent board
Conference room	10	
School hall	11	
Care room	4	
Small machine room	4	
Large machine room	8	

These attenuation values apply in what is known as the reverberant field, which in practice means that you are at least one metre from the device.

Attenuation of fan noise

When silencers are placed directly after the fan, it is very important to follow the Fläkt Woods planning advice carefully. For more information on room attenuation and noise levels, see the section entitled *Planning instructions* in the device catalogue published by Fläkt Woods.



Noise level calculation

The following table shows a complete calculation for the octave bands 63–8000 Hz.

Noise level calculation example in accordance with normal accurate model	Octave band, centre frequency, Hz, according to ISO								L _{wA} dB(A)
	63	125	250	500	1000	2000	4000	8000	
① L _{wA} , fan (page 90)	86								86
② K _{ok} (page 90)	-6	-4	-5	-6	-5	-6	-10	-17	
③ L _{wok} = ① + ②	80	82	81	80	81	80	76	69	86
④ ΔL, bend (page 91)	0	0	0	-1	-2	-3	-3	-3	
⑤ ΔL, branch 1 (page 91)	-8	-8	-8	-8	-8	-8	-8	-8	
⑥ L _{wok} before damper = ③ + ④ + ⑤	72	74	73	71	71	69	65	58	76
⑦ L _{wf} , damper (page 92)	50								
⑧ K ₁ , damper size 016 (page 92)	0	0	0	0	0	0	0	0	
⑨ K ₂ , damper angle 40° (page 92)	-2	-1	-8	-13	-14	-13	-14	-21	
⑩ L _{wok} , damper = ⑦ + ⑧ + ⑨	48	49	42	37	36	37	36	29	44
⑪ L _{wok} after damper = ⑥ + ⑩ (log. add.)	72	74	73	71	71	69	65	58	76
⑫ ΔL, silencer BDER-30-016-030 (page 92)	0	-4	-6	-9	-11	-18	-18	-13	
⑬ ΔL, branch 2 (page 91)	-4	-4	-4	-4	-4	-4	-4	-4	
⑭ Noise attenuation, device, ΔL (page 93)	-25	-22	-17	-13	-12	-11	-11	-11	
⑮ L _{wok} , kanalsystem = ⑪ + ⑫ + ⑬ + ⑭	43	44	46	45	44	36	32	30	47
⑯ L _A , device at vid 4 dB room attenuation (page 93)	25								
⑰ K _{ok} , device (page 93)	-6	-3	-3	0	-1	-1	-9	-12	
⑱ L _{wok} , device = ⑮ + ⑰	19	22	22	25	24	24	16	13	29
⑲ L _{wok} , to room = ⑮ + ⑱ (log. add.)	43	44	46	45	44	36	32	30	47
⑳ Room absorption in dB (page 94)	-4								
㉑ Noise pressure in the room = ⑲ + ⑳	39	40	42	41	40	32	28	26	43
㉒ Correction for A filter	-26	-16	-9	-3	0	1	1	-1	
㉓ L _{pok} , A-weighted noise pressure level = ㉑ + ㉒	13	24	33	38	40	33	29	25	43
㉔ Maximum permitted noise level									32
㉕ Attenuation requirement									11

- The clearly dominant noise is the duct-borne noise – see point ⑮ – which is the same as total, see point ⑲
- Select a silencer at least 11 dB better: 250, 500, 1000 and 2000 Hz: see point ㉕. Carry out a new calculation from ⑫.
- The simplified "fast method" gives – as can be seen – a result which is very close to the one calculated accurately.
- Note: the dB(C) value should also be checked as this is required in BBR 2006, among others.

L_A, dB(A)-figure

Correction for C filter	-1	-	-	-	-	-	-1	-3	
Tolerance in accordance with ISO for specified noise data	±6	±3	±2	±2	±2	±2	±2	±3	±3

1) If this detail is missing from the catalogue, it is calculated as follows:

㉖ L _{wok} , Typical fan	80	82	81	80	81	80	76	69	86
㉗ Noise attenuation device, ΔL	-25	-22	-17	-13	-12	-11	-11	-11	-
㉘ Subtraction ㉖ + ㉗	55	60	64	67	69	69	65	58	74
㉙ ΔL _{wA} , dB(A) ㉖ - ㉘									12

Noise of machine room

Necessary information to allow you to calculate the noise pressure level in the machine room can be found in the Fläkt Woods catalogue. During calculation, the fan's L_{wA} , in this case 86 dB(A), is included. Then find out the value for K_{ok} for the inlet duct and also the values for the attenuation of the sleeve.

Follow the example below:

$$L_{wambient} = L_{wA} + K_{ok} + De$$

De = Reduction figure for sleeve

Noise level calculation example in accordance with normal accurate model	Octave band, centre frequency, Hz, according to ISO								L_{wA} dB(A)
	63	125	250	500	1000	2000	4000	8000	
① L_{wA} , fan	86								86
⑩ K_{ok} inlet duct	-5	-8	-4	-5	-5	-5	-9	-15	
⑪ De, sleeve	-10	-10	-19	-29	-31	-28	-32	-33	
⑫ 2 fans	3	3	3	3	3	3	3	3	
⑬ Noise effect level to surrounding area = ① + ⑩ + ⑪ + ⑫	74	71	66	55	53	56	48	41	63

These values must then be reduced by the attenuation values for the machine room in question: see page 118.

□ FLÄKT WOODS RECOMMENDS

Follow up the work while the project is in progress so that any changes do not affect the original noise requirement. It is important to assign a case manager to noise issues who can monitor the work, and who can specify supplementary measures if so required.



References

ABOUT VENTILATION AND AIR TREATMENT (COMPREHENSIVE)

ASHRAE Manual, USA

- Fundamentals 1997
- HVAC Systems and Equipment 1996
- HVAC Applications 1995
- Refrigeration 1994

ABOUT INDOOR CLIMATE

VVS Tekniska Föreningen

- Klassindelade Inneklimatsystem – Riktlinjer och specifikationer R1
- Klassindelade Inneklimatsystem – Projektering och upphandling A1
- Inneklimat och hälsa H4

SS-EN ISO 7730:2006, Ergonomi för den termiska miljön – Analytisk bestämning och bedömning av termisk komfort med hjälp av indexen PMV och PPD samt kriterier för lokal termisk komfort.

Svensk Ventilation, Bäst i klassen – En bok om lönsamt inneklimat

Svensk Ventilation, Luften inne dödar

Svensk Ventilation, Andnöd

Professor Ole Fanger of the Technical University of Denmark has published a number of essays and research reports relating to air quality. Of these, the following are noteworthy:

- Olf och decipol – de nya enheterna för upplevd luftkvalitet. VVS & Energi 2/88
- Näsan löser mysteriet med det sjuka huset. VVS & Energi 2/88
- Luftens turbulens väsentlig för vår dragupplevelse. VVS & Energi 9/88
- En komfortekvation för inneluftkvalitet. VVS & Energi 11/88

ABOUT NOISE AND NOISE CALCULATIONS

Akustik & Buller av Johnny Andersson, third edition, Ingenjörsförlaget.

FIRE PROTECTION SYSTEMS

Fläkt Woods – Brandskyddshandboken, 2006

ABOUT AIR DISTRIBUTION SYSTEMS AND FANS

VVS Tekniska Föreningen

- Klassindelade luftdistributionssystem – Riktlinjer och specifikationer R2
- Klassindelade luftdistributionssystem – Projektering och upphandling A2
- Klassindelade kanalsystem – Riktlinjer och specifikationer R2:1
- Ventilationssystem – Rensbehov och rensbarhet H6
- Fläktar i kanalsystem H21
- Kanalsystem H22

Kungl Tekniska Högskolan — Klimat och byggnader nr 1/91. Rensning av ventilationskanaler. Chalmers Tekniska Högskola, Lennart Jagemar — Energiekonomi — Val av fläktar och kanalutformning. ASHRAE Standard 90.1–1989. Svensk Ventilation, Eleffektivitet hos fläktar och luftbehandlingsaggregat (V-skript 1995:1 rev).

ABOUT CALCULATION OF COOLING EFFECTS

- ASHRAE Manual, Fundamentals 1997
- VDI Richtlinien, Germany

ENERGY-EFFICIENT PLANNING AND PROCUREMENT

Industrial references

ENEU 94, Anvisningar för energieffektiv projektering och upphandling inom industrin.

ENEU 94K, Anvisningar för energieffektiv projektering och upphandling inom bl.a kommunal verksamhet.

Energimyndigheten, Översikt över effektiva elmotorer

European Directive for Energy Performance of Buildings, EPBD

Sveriges Verkstadsindustrier, VI, Kalkylera med LCC energi

BUILDING REGULATIONS AND INSTRUCTIONS

Boverket — Boverkets Byggregler BBR 2006

Arbetsmiljöverket, AFS 2000:42, Arbetsplatsens utformning

PRODUCT SELECTION PROGRAMMES

www.flaktwoods.com



Terms and definitions

A few important terms

AIR CONDITIONING SYSTEMS

The technical systems required to supply and remove, distribute and (pre)treat air to premises or buildings. Generally, these consist of a central air conditioning unit and an air distribution system.

AIR DISTRIBUTION SYSTEMS

Systems for pressure setup and transport, plus the supply or removal of air, i.e. fans, ducts, post-treatment units and air devices.

DUCT SYSTEMS

Systems for the transport of air and gases, i.e. ducts, post-treatment units and air devices.

INDOOR CLIMATE SYSTEMS

The technical systems required to create a specific indoor climate. Generally consist of air conditioning systems and room systems.

ROOM SYSTEMS

The technical systems which together with the air conditioning system are required to create a specific indoor climate in a room or group of rooms. Consist of post-treatment units with regulation equipment (e.g. VAV units, chilled beams, fan convectors and radiators) for cooling, heating and any air flow regulation, plus supply air and exhaust air devices.

CLIMATE SYSTEM

See "Indoor climate system". Ventilation system
See "Air conditioning system". Often relates to a simpler system without an air cooling option.

VAV SYSTEM (VARIABLE AIR VOLUME)

Indoor climate system with variable supply air and exhaust air flow which uses air as the energy carrier.

CAV SYSTEM (CONSTANT AIR VOLUME)

Indoor climate system with constant supply air and exhaust air flow which uses air as the energy carrier.

DCV SYSTEM (DEMAND CONTROL VENTILATION)

Many spaces are vented specifically with regard to peak loads, but with smart design and control you can control the ventilation as required and reduce energy consumption.

CHILLED BEAM SYSTEM

Indoor climate system which uses water as the energy carrier. A cooling element located in the roof which generally gives off its capacity by allowing the room air to circulate past (through) the cooling surfaces. In combination with supply air, the cooling effect is increased on account of induction.

FAN CONVECTOR SYSTEM (FAN COIL UNIT)

Indoor climate system which uses water as the energy carrier and where the room air is forced to pass through a cooling/heating coil.

LCC (LIFE CYCLE COST)

The Life Cycle Cost (LCC) is calculated as the total cost of a product/installation throughout its entire service life. Investment + operating cost + service and maintenance cost.

VAS CLASS

VAS class 1500 means that a fan consumes 1.5 kW of power to transport 1 m³/s of air.

SFP

Specific fan power output.

SFP_v

SFP for a ventilation unit.

Objects _____ Date _____

Type of building _____ Town _____

Operating time _____

Dimensioned outdoor temperature, winter, DOTw _____ °C Moisture content, winter _____ g/kg

Dimensioned outdoor temperature, summer, DOTs _____ °C Moisture content, summer _____ g/kg

Other common criteria _____

Room no	Description	TECHNICAL CRITERIA				REQUIREMENTS							Comments	
		Floor area m ²	Number of persons	Lighting capacity W	Machine capacity W	Windows	Other information	Temperature values °C	Min air change chs/h	Min air flow l/s	Ind./coil. regulation (IND/ COLL)	Max air rate at t _{max} m/s		Max noise level dB(A)
								t _{ref}	t _{max}	t _{min}				

PROPOSAL FOR TECHNICAL SOLUTION

SHEET

Objects _____ Date _____
Type of building _____ Town _____
Comments _____

Room no	GENERAL							PRODUCT SELECTION			
	Description	Cooling effect W	Max air flow l/s	Min air flow l/s	Heating effect W	System choice/ Typical rooms	Air transfer Mixed/ displaced	Device type Supply Air	Terminal unit type	Device type Exhaust air	Anmärkingar

MOLLIER DIAGRAM FOR HUMID AIR. AIR TEMPERATURE -25 °C TILL +40 °C.

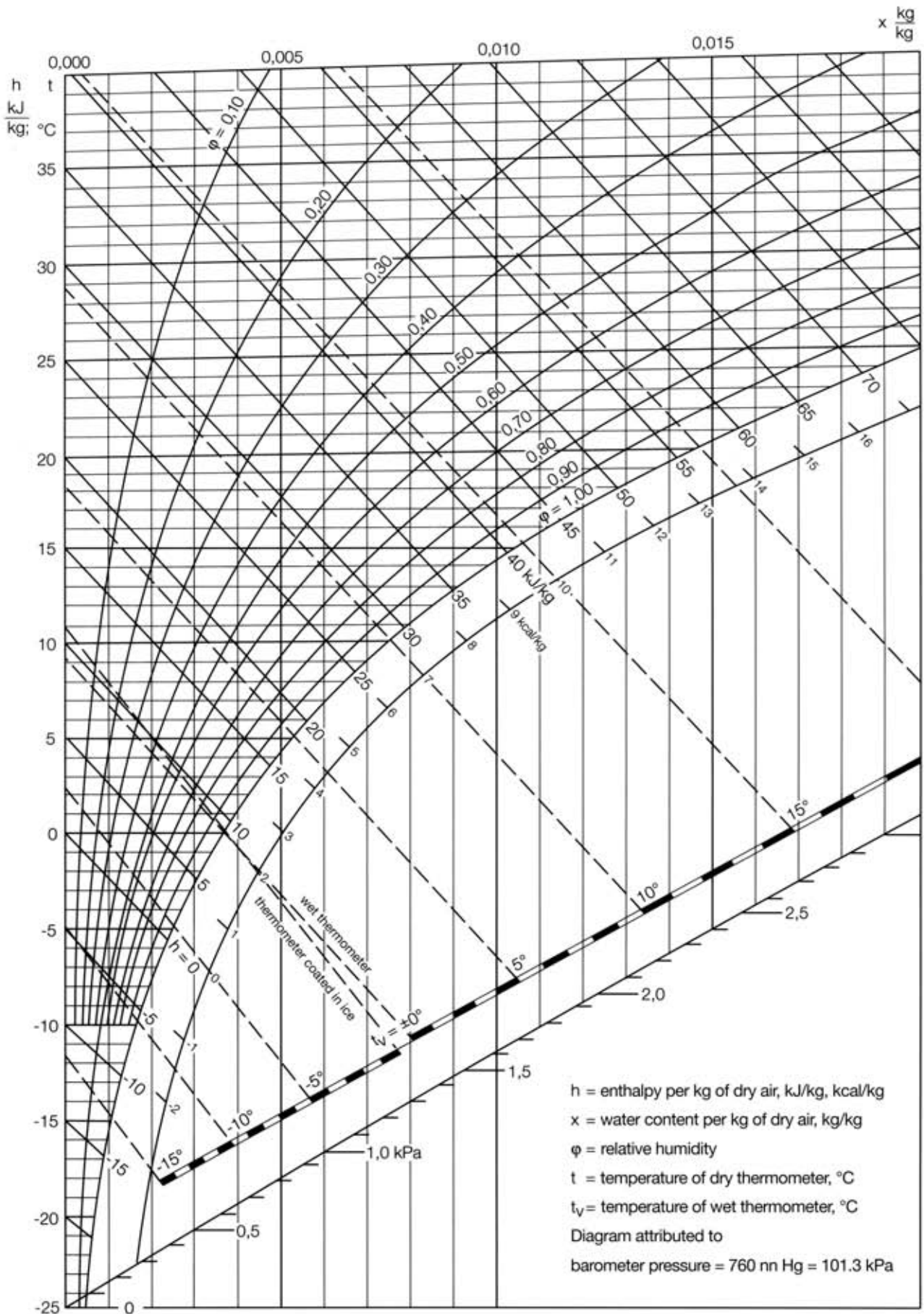

PRESSURE DROP DATA FOR A CIRCULAR DUCT SYSTEM

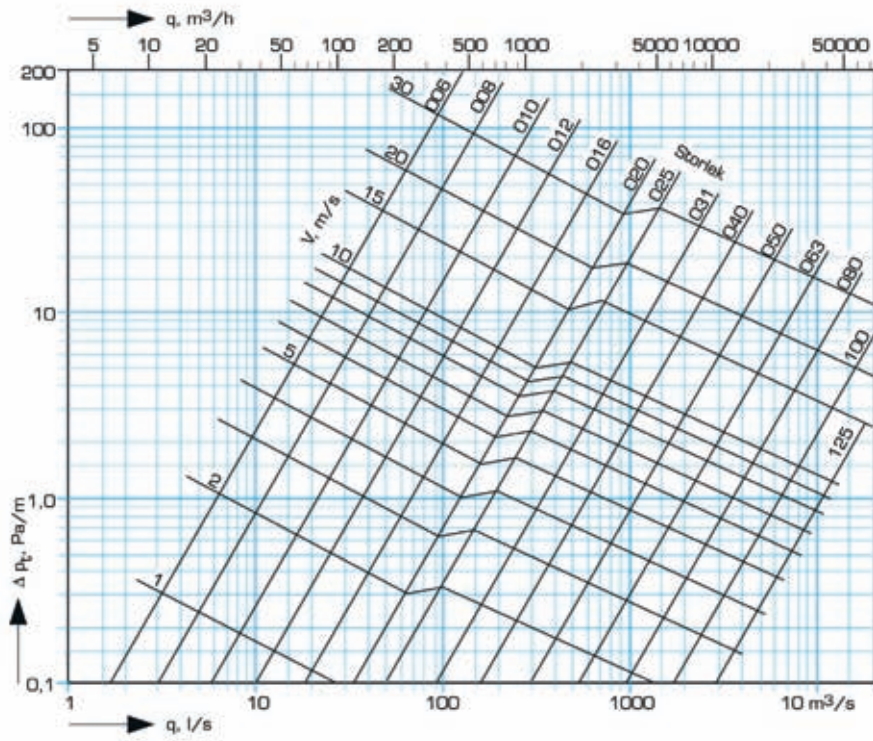

PRESSURE DROP DATA FOR A RECTANGULAR DUCT SYSTEM

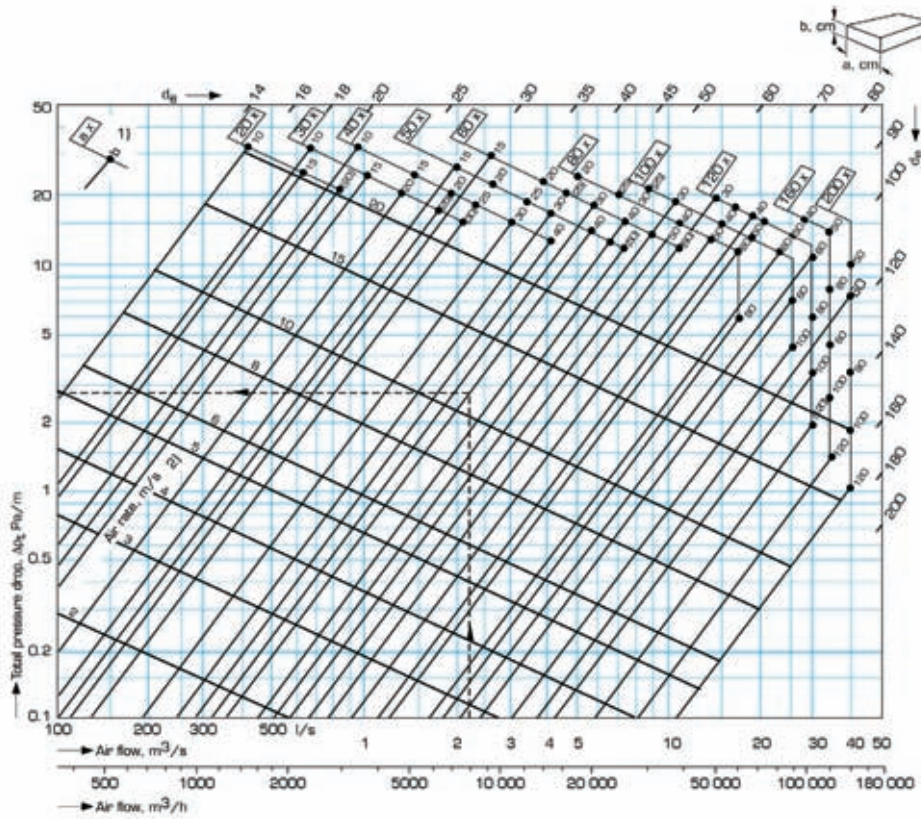

we bring air to life



Fläkt Woods is a global company providing solutions for ventilation and air climate for buildings as well as fan solutions for Industry and Infrastructure applications. Fläkt Woods Group has 20 manufacturing/engineering operations worldwide, sales offices in 30 countries and representation in 95 countries.

Head offices

Buildings Air Climate

Fläkt Woods AB
Kung Hans väg 12
SE-192 68 SOLLENTUNA Sweden
t +46 8 626 49 00
f +46 8 626 73 10

Industry Air Movement

Fläkt Woods
Axial Way
COLCHESTER, CO4 5ZD
United Kingdom
t +44 1206 222 555
f +44 1206 222 777

Sales Offices available World Wide –
See our website for details.

www.flaktwoods.com

Due to a policy of continuous development and improvement the right is reserved to supply products which may differ from those illustrated and described in this publication. Certified dimensions will be supplied on request on receipt of order.

FläktWoods